

CONDENSING UNITS



Seven Models

Cooling Capacities
17,300 to 59,000 BTU/HR
[5.07 kW] to [17.29 kW]

UAND- SERIES

Efficiencies up to 15.00 SEER
in certain matched systems.
Nominal Sizes 1½ to 5 Tons
[5.28 kW] to [17.6 kW]



The Ruud *Achiever*® *Series* High Efficiency UAND- Condensing Unit was designed with performance in mind. These units offer comfort, energy conservation and dependability for single, multi-family and light commercial applications.

The Ruud *Achiever*® *Series* UAND- Condensing Units are the result of an ongoing development program for improved efficiencies. With SEER's up to 15.00, these units continue a tradition of high efficiency.

- Attractive, louvered wrap-around jacket protects the coil from yard hazards and weather extremes. Top grille is steel reinforced for extra strength. Cabinet is powder painted for all-weather protection.
- Air is discharged upward away from bushes and shrubs. The discharge pattern of the top grille provides minimum air restriction, resulting in quiet fan operation.
- Combination Grille/Motor Mount secures the motor to the underside of the discharge grille. The grille protects the motor windings and bearings from rain and snow.
- All controls are accessible by removing one service panel. Removable top grille provides access to the condenser fan motor and condenser coil.
- Single speed motor designed for low speed, quiet, energy-saving operation.
- All models meet or exceed a 1000-hour salt spray test per ASTM B117 Standard Practice for Operating Salt Spray Testing Apparatus.



(IN CERTAIN
MATCHED SYSTEMS)

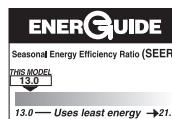



All controls and compressor are accessible for servicing by removal of the service panel.

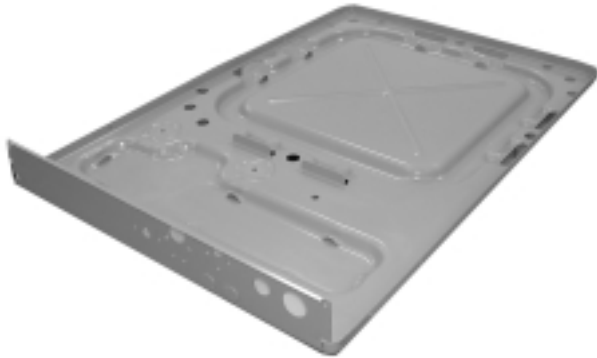

Drawn Painted Base Pan.

Engineering Features

UAND- Series Condensing Units

1. Scroll compressor is hermetically sealed and incorporates internal high temperature motor overload protection, and durable insulation on the motor windings. It is externally mounted on rubber grommets to reduce vibration and noise.
2. Compressors have an internal pressure relief assembly to protect against excessive pressure differential.
3. All refrigerant connections are on the exterior of the unit, located close to the ground for neat appearing installations.
4. Cabinet is constructed of powder painted galvanized steel. The full wraparound louvered grille protects the coil from damage.
5. Copper Tube—Aluminum Fin coils are used on all models.
6. The control box is located in the top corner of the cabinet providing for easy access through a service panel.
7. Service valves are standard on all models.
8. Field connections for power and control wiring are kept separate.
9. Every unit is factory charged and tested.
10. Separate compressor compartment for easy service access.
11. Drawn, painted base pan for extra corrosion resistance and sound reduction.
12. The **UAND** has a **10 year limited compressor warranty** and a liquid line filter drier. The **UAND** also has factory installed low pressure control and high pressure control.

Field Installed Accessories

- **Low Ambient Control**—Cycles outdoor fan to maintain adequate condensing pressures assuring liquid refrigerant flow to the coil. Allows indoor cooling with outdoor temperatures down to 0°F [-17.8°C]. (Model No. RXAD-A04)
It is recommended that this control be installed in units to be operated at outdoor ambient temperatures under 65°F [18°C].
- **Comfort Alert™ Diagnostics**—In operation, Comfort Alert Diagnostics monitors vital data from the Scroll UltraTech™ compressor and thermostat, quickly pinpointing the root cause(s) of any cooling system malfunction—including common electrical problems, compressor defects and broad system faults. (Model No. 42-101504-01)
- **Hard Start Components**—Offer additional starting torque to cover a wide range of voltage and pressure variations. Available through PROSTOCK®
- **Thermostats**



300-Series *
Deluxe Programmable



200-Series *
Programmable



100-Series *
Non-Programmable

400-Series *
Special Applications/Programmable

Brand	Unique Model Number Prefix	Descriptor (3 Characters)	Series (3 Characters)	System (2 Characters)	Type (2 Characters)
UHC	-	TST	101	GE	MS
UHC=Ruud		TST=Thermostat	100=Non-Programmable 200=Programmable 300=Deluxe Programmable 400=Special Applications/Programmable	GE=Gas/Oil/Electric HP=Heat Pump MD=Modulating Furnace DF=Dual Fuel UN=Universal AC/HP/GE	SS=Single-Stage MS=Multi-Stage

* Photos are representative. Actual models may vary.

For detailed thermostat match-up information, see specification sheet form number T22-001.

[] Designates Metric Conversions

SCROLL® COMPRESSOR

The scroll compressor is the key to efficiency for this Ruud model. It's the latest in high-efficiency compressor technology. The advanced scroll compressor offers low noise and vibration characteristics and features tolerance to liquid refrigerant and system contamination. The Scroll also has low start torque, eliminating start problems in the field. And its unique design enables the UAND- condensing unit to perform efficiently, quietly and reliably.



Model Number Identification

<u>U</u>	<u>A</u>	<u>N</u>	<u>D</u>	<u>—</u>	<u>024</u>	<u>J</u>	<u>A</u>	<u>Z</u>
RUUD	REMOTE CONDENSING UNIT	HI-EFFICIENCY (STANDARD)	DESIGN SERIES		COOLING CAPACITY	ELECTRICAL DESIGNATION	VARIATIONS A-SERIES = FULL FEATURED	COOLING CONNECTION FITTING
			D = FOURTH DESIGN		018 = 18,000 BTU/HR [5.27 kW] 024 = 24,000 BTU/HR [7.03 kW] 030 = 30,000 BTU/HR [8.79 kW] 036 = 36,000 BTU/HR [10.55 kW] 042 = 42,000 BTU/HR [12.31 kW] 048 = 48,000 BTU/HR [14.07 kW] 060 = 60,000 BTU/HR [17.58 kW]	J = 208/230V-1-60 C = 208/230V-3-60 D = 460V-3-60 Y = 575V-3-60 (4 & 5 TON ONLY)		Z = SWEAT W/SCROLL
							[] Designates Metric Conversions	

Performance Data @ ARI Standard Conditions—Cooling

Model Numbers		80°F [26.5°C] DB/67°F [19.5°C] WB Indoor Air 95°F [35°C] DB Outdoor Air					Sound Rating dB	Indoor CFM [L/s]
Outdoor Unit UAND-	Indoor Coil and/or Air Handler	Total Capacity BTU/H [kW]	Net Sensible BTU/H [kW]	Net Latent BTU/H [kW]	EER	SEER		
018J*Z	RCFA-H*2417A* ①	18,200 [5.3]	13,150 [3.9]	5,050 [1.5]	11.80	13.15	74	600 [283]
	UBHK-17 (RCBA-24**+RXCT-BCA)	17,300 [5.1]	12,200 [3.6]	5,100 [1.5]	12.25	13.50	74	600 [283]
	UBHK-17 (RCBA-37**+RXCT-BCA)	17,900 [5.2]	12,800 [3.8]	5,100 [1.5]	12.60	14.00	74	600 [283]
	RCFA-A*2414B*	18,200 [5.3]	13,150 [3.9]	5,050 [1.5]	11.80	13.15	74	600 [283]
	RCFA-A*2417B*	18,200 [5.3]	13,150 [3.9]	5,050 [1.5]	11.80	13.15	74	600 [283]
	RCFA-A*2417B* (UGFD-06?MCK?)	18,700 [5.5]	13,500 [4.0]	5,200 [1.5]	13.15	14.00	74	600 [283]
	RCFA-A*2417B* (UGFD-07?MCK?)	18,700 [5.5]	13,500 [4.0]	5,200 [1.5]	13.20	14.00	74	600 [283]
	RCFA-A*2417B* (UGGD-06?MCK?)	18,700 [5.5]	13,550 [4.0]	5,150 [1.5]	13.35	14.50	74	600 [283]
	RCFA-A*2417B* (UGGD-07?MCK?)	18,700 [5.5]	13,500 [4.0]	5,200 [1.5]	13.25	14.50	74	625 [295]
	RCFA-A*2417B* (UGLR-07?AMK?)	18,700 [5.5]	13,550 [4.0]	5,150 [1.5]	13.40	14.50	74	600 [283]
	RCFA-A*2417B* (UGPR-05?BMK?)	18,600 [5.4]	13,450 [3.9]	5,150 [1.5]	13.05	14.00	74	600 [283]
	RCFA-A*2417B* (UGPR-07?AMK?)	18,700 [5.5]	13,500 [4.0]	5,200 [1.5]	13.30	14.50	74	600 [283]
	RCFA-H*2414A*	18,200 [5.3]	13,150 [3.9]	5,050 [1.5]	11.80	13.15	74	600 [283]
	RCFA-H*2417A* (UGFD-06?MCK?)	18,700 [5.5]	13,500 [4.0]	5,200 [1.5]	13.15	14.00	74	600 [283]
	RCFA-H*2417A* (UGFD-07?MCK?)	18,700 [5.5]	13,500 [4.0]	5,200 [1.5]	13.20	14.00	74	600 [283]
	RCFA-H*2417A* (UGGD-06?MCK?)	18,700 [5.5]	13,550 [4.0]	5,150 [1.5]	13.35	14.50	74	600 [283]
	RCFA-H*2417A* (UGGD-07?MCK?)	18,700 [5.5]	13,500 [4.0]	5,200 [1.5]	13.25	14.50	74	625 [295]
	RCFA-H*2417A* (RGJD-06?MCK?)	18,700 [5.5]	13,550 [4.0]	5,150 [1.5]	13.35	14.50	74	600 [283]
	RCFA-H*2417A* (RGJD-07?MCK?)	18,700 [5.5]	13,500 [4.0]	5,200 [1.5]	13.25	14.50	74	625 [295]
	RCFA-H*2417A* (UGLR-07?AMK?)	18,700 [5.5]	13,550 [4.0]	5,150 [1.5]	13.40	14.50	74	600 [283]
	RCFA-H*2417A* (UGPR-05?BMK?)	18,600 [5.4]	13,450 [3.9]	5,150 [1.5]	13.05	14.00	74	600 [283]
	RCFA-H*2417A* (UGPR-07?AMK?)	18,700 [5.5]	13,500 [4.0]	5,200 [1.5]	13.30	14.50	74	600 [283]
	17AHBA24HM (RCHJ-24A1)	18,000 [5.3]	12,650 [3.7]	5,350 [1.6]	12.50	14.00	74	650 [307]
	UBHK-17 (RCHJ-24A1)	18,000 [5.3]	12,800 [3.8]	5,200 [1.5]	12.70	14.00	74	600 [283]
	UBHP-17 (RCHJ-24A1)	18,000 [5.3]	12,650 [3.7]	5,350 [1.6]	12.50	14.00	74	650 [307]
	RCHJ-24A1 (UGFD-06?MCK?)	17,900 [5.2]	12,750 [3.7]	5,150 [1.5]	12.45	14.00	74	600 [283]
	RCHJ-24A1 (UGFD-07?MCK?)	17,900 [5.2]	12,750 [3.7]	5,150 [1.5]	12.45	14.00	74	600 [283]
	RCHJ-24A1 (UGGD-06?MCK?)	17,900 [5.2]	12,800 [3.8]	5,100 [1.5]	12.60	14.20	74	600 [283]
	RCHJ-24A1 (UGGD-07?MCK?)	17,900 [5.2]	12,750 [3.7]	5,150 [1.5]	12.55	14.10	74	625 [295]
	RCQC-2417A	18,500 [5.4]	13,600 [4.0]	4,900 [1.4]	11.70	13.00	74	600 [283]
	RCQC-2417A (UGFD-06?MCK?)	19,000 [5.6]	14,050 [4.1]	4,950 [1.5]	13.05	14.00	74	600 [283]
	RCQC-2417A (UGFD-07?MCK?)	19,000 [5.6]	14,050 [4.1]	4,950 [1.5]	13.10	14.00	74	600 [283]
	RCQC-2417A (UGPR-05?BMK?)	18,900 [5.5]	14,000 [4.1]	4,900 [1.4]	13.00	14.00	74	600 [283]
17AHLA24HM (RCSA-H*2417A*)	18,700 [5.5]	13,500 [4.0]	5,200 [1.5]	13.20	14.50	74	600 [283]	
17AHS18AU (RCSA-H*2417A*)	18,400 [5.4]	13,300 [3.9]	5,100 [1.5]	12.30	13.00	74	600 [283]	
17AHS18HM (RCSA-H*2417A*)	18,400 [5.4]	13,300 [3.9]	5,100 [1.5]	12.30	13.00	74	600 [283]	
UHKA-HM2417 (RCSA-H*2417A*)	19,000 [5.6]	13,700 [4.0]	5,300 [1.6]	13.45	14.50	74	650 [307]	
UHLA-HM2417 (RCSA-H*2417A*)	18,700 [5.5]	13,500 [4.0]	5,200 [1.5]	13.20	14.50	74	600 [283]	
UHSA-HM1817 (RCSA-H*2417A*)	18,400 [5.4]	13,300 [3.9]	5,100 [1.5]	12.30	13.00	74	600 [283]	
024J*Z	RCFA-H*2417A* ①	24,000 [7.0]	16,600 [4.9]	7,400 [2.2]	11.85	13.00	72	775 [366]
	UBHK-17 (RCBA-24**+RXCT-BCB)	22,800 [6.7]	15,300 [4.5]	7,500 [2.2]	12.25	13.50	72	800 [378]
	UBHK-17 (RCBA-37**+RXCT-BCB)	23,800 [7.0]	16,150 [4.7]	7,650 [2.2]	12.70	14.00	72	800 [378]
	RCFA-A*2414B*	24,000 [7.0]	16,600 [4.9]	7,400 [2.2]	11.85	13.00	72	775 [366]
	RCFA-A*2417B*	24,000 [7.0]	16,600 [4.9]	7,400 [2.2]	11.85	13.00	72	775 [366]
	RCFA-A*2417B* (UGFD-06?MCK?)	24,400 [7.1]	16,850 [4.9]	7,550 [2.2]	12.55	14.00	72	800 [378]
	RCFA-A*2417B* (UGFD-07?MCK?)	24,400 [7.1]	16,850 [4.9]	7,550 [2.2]	12.65	14.00	72	800 [378]
	RCFA-A*2417B* (UGGD-06?MCK?)	24,400 [7.1]	16,900 [5.0]	7,500 [2.2]	12.90	14.00	72	800 [378]
	RCFA-A*2417B* (UGGD-07?MCK?)	24,400 [7.1]	16,900 [5.0]	7,500 [2.2]	12.75	14.00	72	800 [378]
	RCFA-A*2417B* (UGLR-07?AMK?)	24,600 [7.2]	16,950 [5.0]	7,650 [2.2]	13.05	14.00	72	800 [378]
	RCFA-A*2417B* (UGPR-05?BMK?)	24,400 [7.1]	16,850 [4.9]	7,550 [2.2]	12.70	14.00	72	775 [366]
	RCFA-A*2417B* (UGPR-07?AMK?)	24,400 [7.1]	16,950 [5.0]	7,450 [2.2]	12.95	14.00	72	800 [378]
	RCFA-H*2414A*	24,000 [7.0]	16,600 [4.9]	7,400 [2.2]	11.85	13.00	72	775 [366]
	RCFA-H*2417A* (UGFD-06?MCK?)	24,400 [7.1]	16,850 [4.9]	7,550 [2.2]	12.55	14.00	72	800 [378]
	RCFA-H*2417A* (UGFD-07?MCK?)	24,400 [7.1]	16,850 [4.9]	7,550 [2.2]	12.65	14.00	72	800 [378]

① Highest sales volume tested combination required by D.O.E. test procedures.

[] Designates Metric Conversions

Performance Data @ ARI Standard Conditions—Cooling (Con't.)

Model Numbers		80°F [26.5°C] DB/67°F [19.5°C] WB Indoor Air 95°F [35°C] DB Outdoor Air					Sound Rating dB	Indoor CFM [L/s]
Outdoor Unit UAND-	Indoor Coil and/or Air Handler	Total Capacity BTU/H [kW]	Net Sensible BTU/H [kW]	Net Latent BTU/H [kW]	EER	SEER		
024J*Z	RCFA-H*2417A* (UGGD-06?MCK?)	24,400 [7.1]	16,900 [5.0]	7,500 [2.2]	12.90	14.00	72	800 [378]
	RCFA-H*2417A* (UGGD-07?MCK?)	24,400 [7.1]	16,900 [5.0]	7,500 [2.2]	12.75	14.00	72	800 [378]
	RCFA-H*2417A* (UGJD-06?MCK?)	24,400 [7.1]	16,900 [5.0]	7,500 [2.2]	12.90	14.00	72	800 [378]
	RCFA-H*2417A* (UGJD-07?MCK?)	24,400 [7.1]	16,900 [5.0]	7,500 [2.2]	12.75	14.00	72	800 [378]
	RCFA-H*2417A* (UGLR-07?AMK?)	24,600 [7.2]	16,950 [5.0]	7,650 [2.2]	13.05	14.00	72	800 [378]
	RCFA-H*2417A* (UGPR-05?BMK?)	24,400 [7.1]	16,850 [4.9]	7,550 [2.2]	12.70	14.00	72	775 [366]
	RCFA-H*2417A* (UGPR-07?AMK?)	24,400 [7.1]	16,950 [5.0]	7,450 [2.2]	12.95	14.00	72	800 [378]
	17AHBA24HM (RCHJ-24A1)	22,600 [6.6]	15,200 [4.5]	7,400 [2.2]	12.05	14.00	72	825 [389]
	UBHK-17 (RCHJ-24A1)	23,800 [7.0]	16,150 [4.7]	7,650 [2.2]	12.70	14.00	72	800 [378]
	UBHP-17 (RCHJ-24A1)	22,600 [6.6]	15,200 [4.5]	7,400 [2.2]	12.05	14.00	72	825 [389]
	RCHJ-24A1 (UGFD-06?MCK?)	23,600 [6.9]	16,000 [4.7]	7,600 [2.2]	12.30	13.50	72	800 [378]
	RCHJ-24A1 (UGFD-07?MCK?)	23,600 [6.9]	16,050 [4.7]	7,550 [2.2]	12.40	13.50	72	800 [378]
	RCHJ-24A1 (UGGD-06?MCK?)	23,800 [7.0]	16,100 [4.7]	7,700 [2.3]	12.60	14.00	72	800 [378]
	RCHJ-24A1 (UGGD-07?MCK?)	23,800 [7.0]	16,100 [4.7]	7,700 [2.3]	12.50	13.50	72	800 [378]
	RCHJ-24A1 (UGJD-06?MCK?)	23,800 [7.0]	16,100 [4.7]	7,700 [2.3]	12.60	14.00	72	800 [378]
	RCHJ-24A1 (UGJD-07?MCK?)	23,800 [7.0]	16,100 [4.7]	7,700 [2.3]	12.50	13.50	72	800 [378]
	RCHJ-24A1 (UGPR-05?BMK?)	23,600 [6.9]	16,050 [4.7]	7,550 [2.2]	12.40	13.50	72	775 [366]
	UBHK-17 (RCHJ-24A2)	23,800 [7.0]	16,150 [4.7]	7,650 [2.2]	12.70	14.00	72	800 [378]
	RCHJ-24A2 (UGFD-06?MCK?)	23,600 [6.9]	16,000 [4.7]	7,600 [2.2]	12.30	13.75	72	800 [378]
	RCHJ-24A2 (UGFD-07?MCK?)	23,600 [6.9]	16,050 [4.7]	7,550 [2.2]	12.40	13.85	72	800 [378]
	RCHJ-24A2 (UGGD-06?MCK?)	23,800 [7.0]	16,100 [4.7]	7,700 [2.3]	12.60	14.05	72	800 [378]
	RCHJ-24A2 (UGGD-07?MCK?)	23,800 [7.0]	16,100 [4.7]	7,700 [2.3]	12.50	13.95	72	800 [378]
	RCHJ-24A2 (UGJD-06?MCK?)	23,800 [7.0]	16,100 [4.7]	7,700 [2.3]	12.60	14.00	72	800 [378]
	RCHJ-24A2 (UGJD-07?MCK?)	23,800 [7.0]	16,100 [4.7]	7,700 [2.3]	12.50	13.50	72	800 [378]
	RCHJ-24A2 (UGPR-05?BMK?)	23,600 [6.9]	16,050 [4.7]	7,550 [2.2]	12.40	13.50	72	775 [366]
	RCQC-2417A	24,400 [7.1]	17,300 [5.1]	7,100 [2.1]	11.85	13.00	72	800 [378]
	RCQC-2417A (UGFD-06?MCK?)	24,800 [7.3]	17,650 [5.2]	7,150 [2.1]	12.70	14.00	72	800 [378]
	RCQC-2417A (UGFD-07?MCK?)	24,800 [7.3]	17,700 [5.2]	7,100 [2.1]	12.80	14.00	72	800 [378]
	RCQC-2417A (UGPR-05?BMK?)	24,800 [7.3]	17,700 [5.2]	7,100 [2.1]	12.80	14.00	72	775 [366]
	17AHS24AU (RCSA-A*2417A*)	24,200 [7.1]	16,700 [4.9]	7,500 [2.2]	12.15	13.00	72	800 [378]
	17AHLA24HM (RCSA-H*2417A*)	24,600 [7.2]	17,050 [5.0]	7,550 [2.2]	13.40	15.00	72	775 [366]
	17AHS24HM (RCSA-H*2417A*)	24,200 [7.1]	16,700 [4.9]	7,500 [2.2]	12.15	13.00	72	800 [378]
	UHKA-HM2417 (RCSA-H*2417A*)	24,800 [7.3]	17,200 [5.0]	7,600 [2.2]	13.10	14.00	72	850 [401]
UHLA-HM2417 (RCSA-H*2417A*)	24,600 [7.2]	17,050 [5.0]	7,550 [2.2]	13.40	15.00	72	775 [366]	
UHSA-HM2417 (RCSA-H*2417A*)	24,200 [7.1]	16,700 [4.9]	7,500 [2.2]	12.15	13.00	72	800 [378]	
030J*Z	RCFA-H*3617A* ①	30,200 [8.8]	21,750 [6.4]	8,450 [2.5]	11.20	13.00	73	1000 [472]
	UBHK-21 (RCBA-37**+RXCT-BCG)	29,600 [8.7]	20,700 [6.1]	8,900 [2.6]	11.95	13.50	73	1000 [472]
	UBHK-21 (RCBA-48**+RXCT-BCG)	30,200 [8.8]	21,400 [6.3]	8,800 [2.6]	12.25	14.20	73	1000 [472]
	RCFA-A*3617B*	30,200 [8.8]	21,750 [6.4]	8,450 [2.5]	11.20	13.00	73	1000 [472]
	RCFA-A*3617B* (UGGD-06?MCK?)	30,600 [9.0]	22,000 [6.4]	8,600 [2.5]	11.70	13.50	73	1000 [472]
	RCFA-A*3617B* (UGLR-07?AMK?)	30,600 [9.0]	22,100 [6.5]	8,500 [2.5]	11.90	13.50	73	1025 [484]
	RCFA-A*3617B* (UGPR-07?AMK?)	30,600 [9.0]	22,100 [6.5]	8,500 [2.5]	11.85	13.50	73	1000 [472]
	RCFA-A*3621B*	30,200 [8.8]	21,750 [6.4]	8,450 [2.5]	11.20	13.00	73	1000 [472]
	RCFA-A*3621B* (UGGD-06?MCK?)	30,600 [9.0]	22,000 [6.4]	8,600 [2.5]	11.70	13.50	73	1000 [472]
	RCFA-A*3621B* (UGLR-07?AMK?)	30,600 [9.0]	22,100 [6.5]	8,500 [2.5]	11.90	13.50	73	1025 [484]
	RCFA-A*3621B* (UGLR-07?BRQ?)	30,800 [9.0]	22,150 [6.5]	8,650 [2.5]	12.25	14.00	73	1000 [472]
	RCFA-A*3621B* (UGPR-07?AMK?)	30,600 [9.0]	22,100 [6.5]	8,500 [2.5]	11.85	13.50	73	1000 [472]
	RCFA-A*3621B* (UGPR-07?BRQ?)	30,800 [9.0]	22,250 [6.5]	8,550 [2.5]	12.25	14.00	73	1000 [472]
	RCFA-H*3617A* (UGGD-06?MCK?)	30,600 [9.0]	22,000 [6.4]	8,600 [2.5]	11.70	13.50	73	1000 [472]
	RCFA-H*3617A* (UGLR-07?AMK?)	30,600 [9.0]	22,100 [6.5]	8,500 [2.5]	11.90	13.50	73	1025 [484]
	RCFA-H*3617A* (UGPR-07?AMK?)	30,600 [9.0]	22,100 [6.5]	8,500 [2.5]	11.85	13.50	73	1000 [472]
	RCFA-H*3621A*	30,200 [8.8]	21,750 [6.4]	8,450 [2.5]	11.20	13.00	73	1000 [472]
	RCFA-H*3621A* (UGGD-06?MCK?)	30,600 [9.0]	22,000 [6.4]	8,600 [2.5]	11.70	13.50	73	1000 [472]
RCFA-H*3621A* (UGJD-06?MCK?)	30,600 [9.0]	22,000 [6.4]	8,600 [2.5]	11.70	13.50	73	1000 [472]	

① Highest sales volume tested combination required by D.O.E. test procedures.

[] Designates Metric Conversions

Performance Data @ ARI Standard Conditions—Cooling (Con't.)

Model Numbers		80°F [26.5°C] DB/67°F [19.5°C] WB Indoor Air 95°F [35°C] DB Outdoor Air					Sound Rating dB	Indoor CFM [L/s]
Outdoor Unit UAND-	Indoor Coil and/or Air Handler	Total Capacity BTU/H [kW]	Net Sensible BTU/H [kW]	Net Latent BTU/H [kW]	EER	SEER		
030J*Z	RCFA-H*3621A* (UGLR-07?AMK?)	30,600 [9.0]	22,100 [6.5]	8,500 [2.5]	11.90	13.50	73	1025 [484]
	RCFA-H*3621A* (UGLR-07?BRQ?)	30,800 [9.0]	22,150 [6.5]	8,650 [2.5]	12.25	14.00	73	1000 [472]
	RCFA-H*3621A* (UGPR-07?BRQ?)	30,800 [9.0]	22,250 [6.5]	8,550 [2.5]	12.25	14.00	73	1000 [472]
	21AHBA36HM (RCHJ-36A1)	30,400 [8.9]	21,250 [6.2]	9,150 [2.7]	12.30	14.00	73	1050 [495]
	UBHK-21 (RCHJ-36A1)	30,200 [8.8]	21,400 [6.3]	8,800 [2.6]	12.25	14.00	73	1000 [472]
	UBHP-21 (RCHJ-36A1)	30,400 [8.9]	21,250 [6.2]	9,150 [2.7]	12.30	14.00	73	1050 [495]
	RCHJ-36A1 (UGFD-06?MCK?)	29,600 [8.7]	20,900 [6.1]	8,700 [2.5]	11.40	13.15	73	1000 [472]
	RCHJ-36A1 (UGFD-07?MCK?)	29,800 [8.7]	21,000 [6.2]	8,800 [2.6]	11.60	13.40	73	1000 [472]
	RCHJ-36A1 (UGGD-06?MCK?)	29,800 [8.7]	21,050 [6.2]	8,750 [2.6]	11.70	13.50	73	1000 [472]
	RCHJ-36A1 (UGGD-07?MCK?)	29,800 [8.7]	21,050 [6.2]	8,750 [2.6]	11.60	13.45	73	1025 [484]
	RCHJ-36A1 (UGJD-06?MCK?)	29,800 [8.7]	21,050 [6.2]	8,750 [2.6]	11.70	13.50	73	1000 [472]
	RCHJ-36A1 (UGJD-07?MCK?)	29,800 [8.7]	21,050 [6.2]	8,750 [2.6]	11.60	13.00	73	1025 [484]
	RCHJ-36A1 (UGPR-05?BMK?)	29,800 [8.7]	21,000 [6.2]	8,800 [2.6]	11.60	13.00	73	1000 [472]
	RCHJ-36A1 (UGPR-07?AMK?)	30,000 [8.8]	21,200 [6.2]	8,800 [2.6]	11.85	13.50	73	1000 [472]
	RCHJ-36A1 (UGPR-07?BRQ?)	30,200 [8.8]	21,350 [6.3]	8,850 [2.6]	12.20	14.00	73	1000 [472]
	RCQC-3617A	30,400 [8.9]	22,250 [6.5]	8,150 [2.4]	11.25	13.00	73	1000 [472]
	RCQC-3621A	30,400 [8.9]	22,250 [6.5]	8,150 [2.4]	11.25	13.00	73	1000 [472]
	RCQC-3621A (UGFD-06?MCK?)	30,600 [9.0]	22,500 [6.6]	8,100 [2.4]	11.65	13.00	73	1000 [472]
	RCQC-3621A (UGFD-07?MCK?)	30,800 [9.0]	22,600 [6.6]	8,200 [2.4]	11.85	13.50	73	1000 [472]
	RCQC-3621A (UGPR-05?BMK?)	30,800 [9.0]	22,600 [6.6]	8,200 [2.4]	11.80	13.50	73	1000 [472]
	RCQC-3621A (UGPR-07?AMK?)	31,000 [9.1]	22,800 [6.7]	8,200 [2.4]	12.10	13.50	73	1000 [472]
	RCQC-3621A (UGPR-07?BRQ?)	31,200 [9.1]	22,950 [6.7]	8,250 [2.4]	12.45	14.00	73	1000 [472]
	17AHSA30AU (RCSA-A*3617A*)	30,200 [8.8]	21,800 [6.4]	8,400 [2.5]	11.55	13.00	73	950 [448]
	17AHLA36HM (RCSA-H*3617A*)	31,000 [9.1]	22,250 [6.5]	8,750 [2.6]	12.30	14.00	73	1000 [472]
	17AHSA30HM (RCSA-H*3617A*)	30,200 [8.8]	21,800 [6.4]	8,400 [2.5]	11.55	13.00	73	950 [448]
	UHKA-HM3617 (RCSA-H*3617A*)	30,800 [9.0]	22,200 [6.5]	8,600 [2.5]	12.15	14.00	73	1025 [484]
UHLA-HM3617 (RCSA-H*3617A*)	31,000 [9.1]	22,250 [6.5]	8,750 [2.6]	12.30	14.00	73	1000 [472]	
UHSA-HM3017 (RCSA-H*3617A*)	30,200 [8.8]	21,800 [6.4]	8,400 [2.5]	11.55	13.00	73	950 [448]	
036C*Z/ D*Z/J*Z	RCFA-H*3617A* ①	34,800 [10.2]	24,550 [7.2]	10,250 [3.0]	11.45	13.00	76	1100 [519]
	RCBA-37**+RXCT-BCD	33,600 [9.8]	23,150 [6.8]	10,450 [3.1]	10.95	12.00	76	1200 [566]
	UBHC-17 (RCBA-37**+RXCT-BCD)	33,600 [9.8]	23,150 [6.8]	10,450 [3.1]	11.00	12.00	76	1200 [566]
	UBHK-21 (RCBA-37**+RXCT-BCD)	34,400 [10.1]	23,900 [7.0]	10,500 [3.1]	12.05	13.50	76	1200 [566]
	RCBA-48**+RXCT-BCH	34,400 [10.1]	24,050 [7.0]	10,350 [3.0]	11.25	13.05	76	1200 [566]
	UBHK-21 (RCBA-48**+RXCT-BCH)	35,200 [10.3]	24,800 [7.3]	10,400 [3.0]	12.35	14.00	76	1200 [566]
	RCFA-A*3617A* (UGLR-07?AMK?)	34,800 [10.2]	24,600 [7.2]	10,200 [3.0]	12.15	13.50	76	1025 [484]
	RCFA-A*3617B*	34,800 [10.2]	24,550 [7.2]	10,250 [3.0]	11.45	13.00	76	1100 [519]
	RCFA-A*3617B* (UGLR-07?AMK?)	34,800 [10.2]	24,600 [7.2]	10,200 [3.0]	12.15	13.50	76	1025 [484]
	RCFA-A*3621B*	34,800 [10.2]	24,550 [7.2]	10,250 [3.0]	11.45	13.00	76	1100 [519]
	RCFA-A*3621B* (UGFD-09?ZCM?)	35,400 [10.4]	25,000 [7.3]	10,400 [3.0]	12.10	13.50	76	1150 [543]
	RCFA-A*3621B* (UGGD-09?ZCM?)	35,600 [10.4]	25,100 [7.4]	10,500 [3.1]	12.10	13.50	76	1175 [554]
	RCFA-A*3621B* (UGGD-10?ZCM?)	35,600 [10.4]	25,100 [7.4]	10,500 [3.1]	12.15	13.50	76	1175 [554]
	RCFA-A*3621B* (UGJD-09?ZCM?)	35,600 [10.4]	25,100 [7.4]	10,500 [3.1]	12.10	13.50	76	1175 [554]
	RCFA-A*3621B* (UGJD-10?ZCM?)	35,600 [10.4]	25,100 [7.4]	10,500 [3.1]	12.15	13.50	76	1175 [554]
	RCFA-A*3621B* (UGLR-07?AMK?)	35,600 [10.4]	25,750 [7.5]	9,850 [2.9]	11.80	13.50	76	1200 [566]
	RCFA-A*3621B* (UGLR-07?BRQ?)	35,000 [10.3]	24,150 [7.1]	10,850 [3.2]	12.40	14.00	76	1000 [472]
	RCFA-A*3621B* (UGPR-07?BRQ?)	35,800 [10.5]	25,250 [7.4]	10,550 [3.1]	12.35	14.00	76	1200 [566]
	RCFA-A*3621B* (UGPR-10?BRM?)	35,800 [10.5]	25,250 [7.4]	10,550 [3.1]	12.15	13.50	76	1225 [578]
	RCFA-H*3617A* (UGLR-07?AMK?)	34,800 [10.2]	24,600 [7.2]	10,200 [3.0]	12.15	13.50	76	1025 [484]
	RCFA-H*3621A*	34,800 [10.2]	24,550 [7.2]	10,250 [3.0]	11.45	13.00	76	1100 [519]
	RCFA-H*3621A* (UGFD-09?ZCM?)	35,400 [10.4]	25,000 [7.3]	10,400 [3.0]	12.10	13.50	76	1150 [543]
	RCFA-H*3621A* (UGGD-09?ZCM?)	35,600 [10.4]	25,100 [7.4]	10,500 [3.1]	12.10	13.50	76	1175 [554]
	RCFA-H*3621A* (UGGD-10?ZCM?)	35,600 [10.4]	25,100 [7.4]	10,500 [3.1]	12.15	13.50	76	1175 [554]
	RCFA-H*3621A* (UGJD-09?ZCM?)	35,600 [10.4]	25,100 [7.4]	10,500 [3.1]	12.10	13.50	76	1175 [554]
	RCFA-H*3621A* (UGJD-10?ZCM?)	35,600 [10.4]	25,100 [7.4]	10,500 [3.1]	12.15	13.50	76	1175 [554]

① Highest sales volume tested combination required by D.O.E. test procedures.

[] Designates Metric Conversions

Performance Data @ ARI Standard Conditions—Cooling (Con't.)

Model Numbers		80°F [26.5°C] DB/67°F [19.5°C] WB Indoor Air 95°F [35°C] DB Outdoor Air					Sound Rating dB	Indoor CFM [L/s]
Outdoor Unit UAND-	Indoor Coil and/or Air Handler	Total Capacity BTU/H [kW]	Net Sensible BTU/H [kW]	Net Latent BTU/H [kW]	EER	SEER		
036C*Z/ D*Z/J*Z	RCFA-H*3621A* (UGLR-07?AMK?)	35,600 [10.4]	25,750 [7.5]	9,850 [2.9]	11.80	13.50	76	1200 [566]
	RCFA-H*3621A* (UGLR-07?BRQ?)	35,000 [10.3]	24,150 [7.1]	10,850 [3.2]	12.40	14.00	76	1000 [472]
	RCFA-H*3621A* (UGPR-07?BRQ?)	35,800 [10.5]	25,250 [7.4]	10,550 [3.1]	12.35	14.00	76	1200 [566]
	RCFA-H*3621A* (UGPR-10?BRM?)	35,800 [10.5]	25,250 [7.4]	10,550 [3.1]	12.15	13.50	76	1225 [578]
	RCHJ-36A1	34,400 [10.1]	24,050 [7.0]	10,350 [3.0]	11.25	13.00	76	1200 [566]
	21AHBA36HM (RCHJ-36A1)	35,400 [10.4]	25,150 [7.4]	10,250 [3.0]	12.55	14.00	76	1225 [578]
	UBHK-21 (RCHJ-36A1)	35,200 [10.3]	24,800 [7.3]	10,400 [3.0]	12.35	14.00	76	1200 [566]
	UBHP-21 (RCHJ-36A1)	35,400 [10.4]	25,150 [7.4]	10,250 [3.0]	12.55	14.00	76	1225 [578]
	RCHJ-36A1 (UGFD-06?MCK?)	34,600 [10.1]	24,150 [7.1]	10,450 [3.1]	11.35	13.00	76	1175 [554]
	RCHJ-36A1 (UGFD-07?MCK?)	34,400 [10.1]	24,150 [7.1]	10,250 [3.0]	11.35	13.00	76	1200 [566]
	RCHJ-36A1 (UGFD-09?ZCM?)	34,800 [10.2]	24,750 [7.3]	10,050 [2.9]	12.15	14.00	76	1150 [543]
	RCHJ-36A1 (UGFD-10?ZCM?)	35,000 [10.3]	24,650 [7.2]	10,350 [3.0]	12.10	14.00	76	1175 [554]
	RCHJ-36A1 (UGFD-12?RCM?)	35,000 [10.3]	24,700 [7.2]	10,300 [3.0]	12.20	14.00	76	1225 [578]
	RCHJ-36A1 (UGGD-06?MCK?)	34,600 [10.1]	24,250 [7.1]	10,350 [3.0]	11.50	13.00	76	1225 [578]
	RCHJ-36A1 (UGGD-07?MCK?)	34,600 [10.1]	24,150 [7.1]	10,450 [3.1]	11.40	13.00	76	1225 [578]
	RCHJ-36A1 (UGGD-09?ZCM?)	35,000 [10.3]	24,700 [7.2]	10,300 [3.0]	12.20	14.00	76	1175 [554]
	RCHJ-36A1 (UGGD-10?ZCM?)	35,000 [10.3]	24,700 [7.2]	10,300 [3.0]	12.20	14.00	76	1175 [554]
	RCHJ-36A1 (UGGD-12?RCM?)	35,200 [10.3]	24,800 [7.3]	10,400 [3.0]	12.30	14.00	76	1225 [578]
	RCHJ-36A1 (UGJD-06?MCK?)	34,600 [10.1]	24,250 [7.1]	10,350 [3.0]	11.50	13.00	76	1225 [578]
	RCHJ-36A1 (UGJD-07?MCK?)	34,600 [10.1]	24,150 [7.1]	10,450 [3.1]	11.40	13.00	76	1225 [578]
	RCHJ-36A1 (UGJD-09?ZCM?)	35,000 [10.3]	24,700 [7.2]	10,300 [3.0]	12.20	14.00	76	1175 [554]
	RCHJ-36A1 (UGJD-10?ZCM?)	35,000 [10.3]	24,700 [7.2]	10,300 [3.0]	12.20	14.00	76	1175 [554]
	RCHJ-36A1 (UGJD-12?RCM?)	35,200 [10.3]	24,800 [7.3]	10,400 [3.0]	12.30	14.00	76	1225 [578]
	RCHJ-36A1 (UGPR-05?BMK?)	34,600 [10.1]	24,200 [7.1]	10,400 [3.0]	11.45	13.00	76	1200 [566]
	RCHJ-36A1 (UGPR-07?AMK?)	34,800 [10.2]	24,550 [7.2]	10,250 [3.0]	11.90	13.50	76	1200 [566]
	RCHJ-36A1 (UGPR-07?BRQ?)	35,200 [10.3]	24,850 [7.3]	10,350 [3.0]	12.40	14.00	76	1200 [566]
	RCHJ-36A1 (UGPR-10?BRM?)	35,000 [10.3]	24,750 [7.3]	10,250 [3.0]	12.25	14.00	76	1225 [578]
	RCHJ-36A1 (UGPR-12?ARM?)	35,400 [10.4]	24,800 [7.3]	10,600 [3.1]	12.40	14.00	76	1250 [590]
	RCHJ-36A2	34,400 [10.1]	24,050 [7.0]	10,350 [3.0]	11.25	13.05	76	1200 [566]
	UBHK-21 (RCHJ-36A2)	35,200 [10.3]	24,800 [7.3]	10,400 [3.0]	12.35	14.00	76	1200 [566]
	RCHJ-36A2 (UGFD-06?MCK?)	34,600 [10.1]	24,150 [7.1]	10,450 [3.1]	11.35	13.10	76	1175 [554]
	RCHJ-36A2 (UGFD-07?MCK?)	34,400 [10.1]	24,150 [7.1]	10,250 [3.0]	11.35	13.05	76	1200 [566]
	RCHJ-36A2 (UGFD-09?ZCM?)	34,800 [10.2]	24,750 [7.3]	10,050 [2.9]	12.15	14.10	76	1150 [543]
	RCHJ-36A2 (UGFD-10?ZCM?)	35,000 [10.3]	24,650 [7.2]	10,350 [3.0]	12.10	14.00	76	1175 [554]
	RCHJ-36A2 (UGFD-12?RCM?)	35,000 [10.3]	24,700 [7.2]	10,300 [3.0]	12.20	14.10	76	1225 [578]
	RCHJ-36A2 (UGGD-06?MCK?)	34,600 [10.1]	24,250 [7.1]	10,350 [3.0]	11.50	13.25	76	1225 [578]
	RCHJ-36A2 (UGGD-07?MCK?)	34,600 [10.1]	24,150 [7.1]	10,450 [3.1]	11.40	13.10	76	1225 [578]
	RCHJ-36A2 (UGGD-09?ZCM?)	35,000 [10.3]	24,700 [7.2]	10,300 [3.0]	12.20	14.15	76	1175 [554]
	RCHJ-36A2 (UGGD-10?ZCM?)	35,000 [10.3]	24,700 [7.2]	10,300 [3.0]	12.20	14.15	76	1175 [554]
	RCHJ-36A2 (UGGD-12?RCM?)	35,200 [10.3]	24,800 [7.3]	10,400 [3.0]	12.30	14.25	76	1225 [578]
RCHJ-36A2 (UGJD-06?MCK?)	34,600 [10.1]	24,250 [7.1]	10,350 [3.0]	11.50	13.00	76	1225 [578]	
RCHJ-36A2 (UGJD-07?MCK?)	34,600 [10.1]	24,150 [7.1]	10,450 [3.1]	11.40	13.00	76	1225 [578]	
RCHJ-36A2 (UGJD-09?ZCM?)	35,000 [10.3]	24,700 [7.2]	10,300 [3.0]	12.20	14.00	76	1175 [554]	
RCHJ-36A2 (UGJD-10?ZCM?)	35,000 [10.3]	24,700 [7.2]	10,300 [3.0]	12.20	14.00	76	1175 [554]	
RCHJ-36A2 (UGJD-12?RCM?)	35,200 [10.3]	24,800 [7.3]	10,400 [3.0]	12.30	14.00	76	1225 [578]	
RCHJ-36A2 (UGPR-05?BMK?)	34,600 [10.1]	24,200 [7.1]	10,400 [3.0]	11.45	13.00	76	1200 [566]	
RCHJ-36A2 (UGPR-07?AMK?)	34,800 [10.2]	24,550 [7.2]	10,250 [3.0]	11.90	13.50	76	1200 [566]	
RCHJ-36A2 (UGPR-07?BRQ?)	35,200 [10.3]	24,850 [7.3]	10,350 [3.0]	12.40	14.00	76	1200 [566]	
RCHJ-36A2 (UGPR-10?BRM?)	35,000 [10.3]	24,750 [7.3]	10,250 [3.0]	12.25	14.00	76	1225 [578]	
RCHJ-36A2 (UGPR-12?ARM?)	35,400 [10.4]	24,800 [7.3]	10,600 [3.1]	12.40	14.00	76	1250 [590]	
RCQC-3617A	35,600 [10.4]	25,900 [7.6]	9,700 [2.8]	11.55	13.00	76	1200 [566]	
RCQC-3621A	35,600 [10.4]	25,900 [7.6]	9,700 [2.8]	11.55	13.00	76	1200 [566]	
RCQC-3621A (UGFD-09?ZCM?)	36,000 [10.5]	26,500 [7.8]	9,500 [2.8]	12.40	14.00	76	1150 [543]	
RCQC-3621A (UGFD-10?ZCM?)	36,000 [10.5]	26,400 [7.7]	9,600 [2.8]	12.30	14.00	76	1175 [554]	

① Highest sales volume tested combination required by D.O.E. test procedures.

[] Designates Metric Conversions

Performance Data @ ARI Standard Conditions—Cooling (Con't.)

Model Numbers		80°F [26.5°C] DB/67°F [19.5°C] WB Indoor Air 95°F [35°C] DB Outdoor Air					Sound Rating dB	Indoor CFM [L/s]
Outdoor Unit UAND-	Indoor Coil and/or Air Handler	Total Capacity BTU/H [kW]	Net Sensible BTU/H [kW]	Net Latent BTU/H [kW]	EER	SEER		
036C*Z/ D*Z/J*Z	RCQC-3621A (UGPR-07?AMK?)	36,000 [10.5]	26,300 [7.7]	9,700 [2.8]	12.15	13.50	76	1200 [566]
	RCQC-3621A (UGPR-07?BRQ?)	36,200 [10.6]	26,600 [7.8]	9,600 [2.8]	12.65	14.00	76	1200 [566]
	RCQC-3621A (UGPR-10?BRM?)	36,200 [10.6]	26,500 [7.8]	9,700 [2.8]	12.45	14.00	76	1225 [578]
	17AHS36AU (RCSA-A*3617A*)	35,000 [10.3]	24,650 [7.2]	10,350 [3.0]	11.75	13.00	76	1100 [519]
	17AHLA36HM (RCSA-H*3617A*)	35,800 [10.5]	25,300 [7.4]	10,500 [3.1]	12.40	14.00	76	1200 [566]
	17AHS36HM (RCSA-H*3617A*)	35,000 [10.3]	24,650 [7.2]	10,350 [3.0]	11.75	13.00	76	1100 [519]
	UHKA-HM3617 (RCSA-H*3617A*)	35,800 [10.5]	25,300 [7.4]	10,500 [3.1]	12.25	14.00	76	1225 [578]
	UHLA-HM3617 (RCSA-H*3617A*)	35,800 [10.5]	25,300 [7.4]	10,500 [3.1]	12.40	14.00	76	1200 [566]
	UHSA-HM3617 (RCSA-H*3617A*)	35,000 [10.3]	24,650 [7.2]	10,350 [3.0]	11.75	13.00	76	1100 [519]
	UHSA-HM3621 (RCSA-H*3621A*)	35,000 [10.3]	24,650 [7.2]	10,350 [3.0]	11.75	13.00	76	1100 [519]
RCTA-A036		34,000 [10.0]	24,250 [7.1]	9,750 [2.9]	11.10	12.00	76	1200 [566]
042C*Z/ D*Z/J*Z	RCFA-H*4821A* ①	42,500 [12.5]	31,050 [9.1]	11,450 [3.4]	11.60	13.00	76	1400 [661]
	UBHC-21 (RCBA-48**+RXCT-BCE)	40,000 [11.7]	27,600 [8.1]	12,400 [3.6]	11.05	12.00	76	1400 [661]
	UBHK-24 (RCBA-48**+RXCT-BCE)	41,000 [12.0]	28,550 [8.4]	12,450 [3.6]	12.25	13.50	76	1400 [661]
	RCBA-60**+RXCT-BCJ	40,500 [11.9]	28,400 [8.3]	12,100 [3.5]	11.20	12.00	76	1400 [661]
	UBHK-24 (RCBA-60**+RXCT-BCJ)	41,500 [12.2]	29,350 [8.6]	12,150 [3.6]	12.40	14.00	76	1400 [661]
	RCFA-A*4821B*	42,500 [12.5]	31,050 [9.1]	11,450 [3.4]	11.60	13.00	76	1400 [661]
	RCFA-A*4821B* (UGLR-10?BRM?)	43,000 [12.6]	31,250 [9.2]	11,750 [3.4]	12.35	14.00	76	1375 [649]
	RCFA-A*4821B* (UGPR-07?BRQ?)	43,000 [12.6]	31,200 [9.1]	11,800 [3.5]	12.30	13.50	76	1400 [661]
	RCFA-A*4824B*	42,500 [12.5]	31,050 [9.1]	11,450 [3.4]	11.60	13.00	76	1400 [661]
	RCFA-A*4824B* (UGLR-10?BRM?)	43,000 [12.6]	31,250 [9.2]	11,750 [3.4]	12.35	14.00	76	1375 [649]
	RCFA-A*4824B* (UGLR-12?ARM?)	43,000 [12.6]	31,200 [9.1]	11,800 [3.5]	12.30	13.50	76	1425 [672]
	RCFA-A*4824B* (UGPR-07?BRQ?)	43,000 [12.6]	31,200 [9.1]	11,800 [3.5]	12.30	13.50	76	1400 [661]
	RCFA-A*4824B* (UGPR-12?ARM?)	43,000 [12.6]	31,200 [9.1]	11,800 [3.5]	12.30	13.50	76	1400 [661]
	RCFA-H*4821A* (UGLR-10?BRM?)	43,000 [12.6]	31,250 [9.2]	11,750 [3.4]	12.35	14.00	76	1375 [649]
	RCFA-H*4821A* (UGPR-07?BRQ?)	43,000 [12.6]	31,200 [9.1]	11,800 [3.5]	12.30	13.50	76	1400 [661]
	RCFA-H*4824A*	42,500 [12.5]	31,050 [9.1]	11,450 [3.4]	11.60	13.00	76	1400 [661]
	RCFA-H*4824A* (UGLR-10?BRM?)	43,000 [12.6]	31,250 [9.2]	11,750 [3.4]	12.35	14.00	76	1375 [649]
	RCFA-H*4824A* (UGLR-12?ARM?)	43,000 [12.6]	31,200 [9.1]	11,800 [3.5]	12.30	13.50	76	1425 [672]
	RCFA-H*4824A* (UGPR-07?BRQ?)	43,000 [12.6]	31,200 [9.1]	11,800 [3.5]	12.30	13.50	76	1400 [661]
	RCFA-H*4824A* (UGPR-12?ARM?)	43,000 [12.6]	31,200 [9.1]	11,800 [3.5]	12.30	13.50	76	1400 [661]
	RCHJ-48A1	40,500 [11.9]	28,400 [8.3]	12,100 [3.5]	11.20	12.00	76	1400 [661]
	24AHBA48HM (RCHJ-48A1)	40,500 [11.9]	28,200 [8.3]	12,300 [3.6]	12.10	14.00	76	1400 [661]
	UBHK-24 (RCHJ-48A1)	41,500 [12.2]	29,350 [8.6]	12,150 [3.6]	12.40	14.00	76	1400 [661]
	UBHP-24 (RCHJ-48A1)	40,500 [11.9]	28,200 [8.3]	12,300 [3.6]	12.10	14.00	76	1400 [661]
	RCHJ-48A1 (UGFD-09?ZCM?)	40,500 [11.9]	28,950 [8.5]	11,550 [3.4]	11.75	13.35	76	1325 [625]
	RCHJ-48A1 (UGFD-10?ZCM?)	40,500 [11.9]	28,850 [8.5]	11,650 [3.4]	11.60	13.15	76	1325 [625]
	RCHJ-48A1 (UGFD-12?RCM?)	41,500 [12.2]	28,800 [8.4]	12,700 [3.7]	11.75	13.35	76	1475 [696]
	RCHJ-48A1 (UGGD-09?ZCM?)	41,000 [12.0]	28,850 [8.5]	12,150 [3.6]	11.75	13.35	76	1425 [672]
	RCHJ-48A1 (UGGD-10?ZCM?)	41,000 [12.0]	28,900 [8.5]	12,100 [3.5]	11.75	13.35	76	1425 [672]
	RCHJ-48A1 (UGGD-12?RCM?)	41,500 [12.2]	29,000 [8.5]	12,500 [3.7]	12.00	13.65	76	1450 [684]
	RCHJ-48A1 (UGJD-09?ZCM?)	41,000 [12.0]	28,850 [8.5]	12,150 [3.6]	11.75	13.00	76	1425 [672]
	RCHJ-48A1 (UGJD-10?ZCM?)	41,000 [12.0]	28,900 [8.5]	12,100 [3.5]	11.75	13.00	76	1425 [672]
	RCHJ-48A1 (UGJD-12?RCM?)	41,500 [12.2]	29,000 [8.5]	12,500 [3.7]	12.00	13.50	76	1450 [684]
	RCHJ-48A1 (UGPR-07?BRQ?)	41,000 [12.0]	29,150 [8.5]	11,850 [3.5]	12.10	13.50	76	1400 [661]
	RCHJ-48A1 (UGPR-10?BRM?)	41,000 [12.0]	28,950 [8.5]	12,050 [3.5]	11.85	13.50	76	1425 [672]
	RCHJ-48A1 (UGPR-12?ARM?)	41,000 [12.0]	29,150 [8.5]	11,850 [3.5]	12.10	13.50	76	1400 [661]
	RCQC-4821A	42,000 [12.3]	30,900 [9.1]	11,100 [3.3]	11.55	13.00	76	1400 [661]
	RCQC-4821A (UGPR-07?BRQ?)	42,500 [12.5]	31,450 [9.2]	11,050 [3.2]	12.25	13.50	76	1400 [661]
	RCQC-4824A	42,000 [12.3]	30,900 [9.1]	11,100 [3.3]	11.55	13.00	76	1400 [661]
	RCQC-4824A (UGPR-07?BRQ?)	42,500 [12.5]	31,500 [9.2]	11,000 [3.2]	12.35	13.50	76	1400 [661]
RCQC-4824A (UGPR-12?ARM?)	42,500 [12.5]	31,500 [9.2]	11,000 [3.2]	12.35	13.50	76	1400 [661]	
RCQC-4921A	43,000 [12.6]	32,400 [9.5]	10,600 [3.1]	11.85	13.00	76	1400 [661]	
RCQC-4921A (UGPR-07?BRQ?)	43,500 [12.7]	32,950 [9.7]	10,550 [3.1]	12.40	14.00	76	1400 [661]	

① Highest sales volume tested combination required by D.O.E. test procedures.

[] Designates Metric Conversions

Performance Data @ ARI Standard Conditions—Cooling (Con't.)

Model Numbers		80°F [26.5°C] DB/67°F [19.5°C] WB Indoor Air 95°F [35°C] DB Outdoor Air					Sound Rating dB	Indoor CFM [L/s]
Outdoor Unit UAND-	Indoor Coil and/or Air Handler	Total Capacity BTU/H [kW]	Net Sensible BTU/H [kW]	Net Latent BTU/H [kW]	EER	SEER		
042C*Z/ D*Z/J*Z	RCQC-4924A	43,000 [12.6]	32,400 [9.5]	10,600 [3.1]	11.85	13.00	76	1400 [661]
	RCQC-4924A (UGPR-07?BRQ?)	43,500 [12.7]	33,000 [9.7]	10,500 [3.1]	12.50	14.00	76	1400 [661]
	RCQC-4924A (UGPR-12?ARM?)	43,500 [12.7]	33,000 [9.7]	10,500 [3.1]	12.50	14.00	76	1400 [661]
	21AHLA48HM (RCSA-H*4821A*)	43,000 [12.6]	31,350 [9.2]	11,650 [3.4]	12.60	14.00	76	1400 [661]
	21AHS42AU (RCSA-H*4821A*)	42,000 [12.3]	30,600 [9.0]	11,400 [3.3]	11.85	13.00	76	1300 [613]
	21AHS42HM (RCSA-H*4821A*)	42,000 [12.3]	30,600 [9.0]	11,400 [3.3]	11.85	13.00	76	1300 [613]
	UHKA-HM4821 (RCSA-H*4821A*)	43,000 [12.6]	31,300 [9.2]	11,700 [3.4]	12.50	14.00	76	1400 [661]
	UHLA-HM4821 (RCSA-H*4821A*)	43,000 [12.6]	31,350 [9.2]	11,650 [3.4]	12.60	14.00	76	1400 [661]
	UHSA-HM4221 (RCSA-H*4821A*)	42,000 [12.3]	30,600 [9.0]	11,400 [3.3]	11.85	13.00	76	1300 [613]
RCTA-A048		39,500 [11.6]	28,250 [8.3]	11,250 [3.3]	11.00	12.00	76	1400 [661]
048C*Z/ D*Z/J*Z/Y*Z	RCFA-H*4821A* ①	47,500 [13.9]	34,300 [10.0]	13,200 [3.9]	11.70	13.00	76	1550 [731]
	RCBA-48**+RXCT-BCE	45,000 [13.2]	31,500 [9.2]	13,500 [4.0]	11.10	12.00	76	1600 [755]
	UBHC-21 (RCBA-48**+RXCT-BCE)	45,000 [13.2]	31,350 [9.2]	13,650 [4.0]	10.90	12.00	76	1600 [755]
	UBHK-24 (RCBA-48**+RXCT-BCE)	45,500 [13.3]	32,250 [9.4]	13,250 [3.9]	11.85	13.00	76	1600 [755]
	RCBA-60**+RXCT-BCK	46,000 [13.5]	32,400 [9.5]	13,600 [4.0]	11.25	12.00	76	1600 [755]
	UBHK-24 (RCBA-60**+RXCT-BCK)	47,000 [13.8]	33,200 [9.7]	13,800 [4.0]	12.15	13.50	76	1600 [755]
	RCFA-A*4821B*	47,500 [13.9]	34,300 [10.0]	13,200 [3.9]	11.70	13.00	76	1550 [731]
	RCFA-A*4824B*	47,500 [13.9]	34,300 [10.0]	13,200 [3.9]	11.70	13.00	76	1550 [731]
	RCFA-H*4824A*	47,500 [13.9]	34,300 [10.0]	13,200 [3.9]	11.70	13.00	76	1550 [731]
	RCHJ-48A1	46,000 [13.5]	32,400 [9.5]	13,600 [4.0]	11.25	12.00	76	1600 [755]
	24AHBA48HM (RCHJ-48A1)	46,500 [13.6]	32,400 [9.5]	14,100 [4.1]	12.10	13.50	76	1600 [755]
	UBHK-24 (RCHJ-48A1)	47,000 [13.8]	33,200 [9.7]	13,800 [4.0]	12.15	13.50	76	1600 [755]
	UBHP-24 (RCHJ-48A1)	46,500 [13.6]	32,400 [9.5]	14,100 [4.1]	12.10	13.50	76	1600 [755]
	RCHJ-48A1 (UGFD-12?RCM?)	46,500 [13.6]	32,650 [9.6]	13,850 [4.1]	11.60	13.00	76	1650 [779]
	RCHJ-48A1 (UGGD-12?RCM?)	46,500 [13.6]	32,600 [9.6]	13,900 [4.1]	11.55	13.00	76	1650 [779]
	RCHJ-48A1 (UGJD-12?RCM?)	46,500 [13.6]	32,600 [9.6]	13,900 [4.1]	11.55	13.00	76	1650 [779]
	RCHJ-48A1 (UGPR-07?BRQ?)	46,500 [13.6]	32,900 [9.6]	13,600 [4.0]	11.75	13.00	76	1625 [767]
	RCHJ-48A1 (UGPR-10?BRM?)	46,500 [13.6]	32,650 [9.6]	13,850 [4.1]	11.55	13.00	76	1625 [767]
	RCHJ-48A1 (UGPR-12?ARM?)	46,500 [13.6]	32,950 [9.7]	13,550 [4.0]	11.85	13.00	76	1575 [743]
	RCHJ-48A2	46,000 [13.5]	32,400 [9.5]	13,600 [4.0]	11.25	12.00	76	1600 [755]
	UBHK-24 (RCHJ-48A2)	47,000 [13.8]	33,200 [9.7]	13,800 [4.0]	12.15	13.50	76	1600 [755]
	RCHJ-48A2 (UGFD-12?RCM?)	46,500 [13.6]	32,650 [9.6]	13,850 [4.1]	11.60	13.10	76	1650 [779]
	RCHJ-48A2 (UGGD-12?RCM?)	46,500 [13.6]	32,600 [9.6]	13,900 [4.1]	11.55	13.05	76	1650 [779]
	RCHJ-48A2 (UGJD-12?RCM?)	46,500 [13.6]	32,600 [9.6]	13,900 [4.1]	11.55	13.00	76	1650 [779]
	RCHJ-48A2 (UGPR-07?BRQ?)	46,500 [13.6]	32,900 [9.6]	13,600 [4.0]	11.75	13.00	76	1625 [767]
	RCHJ-48A2 (UGPR-10?BRM?)	46,500 [13.6]	32,650 [9.6]	13,850 [4.1]	11.55	13.00	76	1625 [767]
	RCHJ-48A2 (UGPR-12?ARM?)	46,500 [13.6]	32,950 [9.7]	13,550 [4.0]	11.85	13.00	76	1575 [743]
	RCQC-4821A	48,000 [14.1]	35,150 [10.3]	12,850 [3.8]	11.60	13.00	76	1600 [755]
	RCQC-4824A	48,000 [14.1]	35,150 [10.3]	12,850 [3.8]	11.60	13.00	76	1600 [755]
	RCQC-4924A	49,000 [14.4]	36,500 [10.7]	12,500 [3.7]	11.95	13.00	76	1540 [727]
	RCQC-4924A (UGFD-12?RCM?)	49,000 [14.4]	36,900 [10.8]	12,100 [3.5]	12.30	13.50	76	1475 [696]
	RCQC-4924A (UGPR-07?BRQ?)	49,500 [14.5]	36,750 [10.8]	12,750 [3.7]	12.35	13.50	76	1625 [767]
	RCQC-4924A (UGPR-12?ARM?)	49,500 [14.5]	36,850 [10.8]	12,650 [3.7]	12.35	13.50	76	1575 [743]
	21AHS48AU (RCSA-A*4821A*)	47,500 [13.9]	34,200 [10.0]	13,300 [3.9]	11.75	13.00	76	1525 [720]
	21AHLA48HM (RCSA-H*4821A*)	48,000 [14.1]	34,800 [10.2]	13,200 [3.9]	12.35	13.50	76	1600 [755]
	21AHS48HM (RCSA-H*4821A*)	47,500 [13.9]	34,200 [10.0]	13,300 [3.9]	11.75	13.00	76	1525 [720]
	UHKA-HM4821 (RCSA-H*4821A*)	48,000 [14.1]	34,550 [10.1]	13,450 [3.9]	12.20	13.50	76	1575 [743]
	UHLA-HM4821 (RCSA-H*4821A*)	48,000 [14.1]	34,800 [10.2]	13,200 [3.9]	12.35	13.50	76	1600 [755]
	UHSA-HM4821 (RCSA-H*4821A*)	47,500 [13.9]	34,200 [10.0]	13,300 [3.9]	11.75	13.00	76	1525 [720]
	24AHLA48HM (RCSA-H*4824A*)	48,500 [14.2]	35,050 [10.3]	13,450 [3.9]	12.70	14.00	76	1625 [767]
	UHKA-HM4824 (RCSA-H*4824A*)	48,500 [14.2]	35,050 [10.3]	13,450 [3.9]	12.65	14.00	76	1625 [767]
	UHLA-HM4824 (RCSA-H*4824A*)	48,500 [14.2]	35,050 [10.3]	13,450 [3.9]	12.70	14.00	76	1625 [767]
UHSA-HM4824 (RCSA-H*4824A*)	47,500 [13.9]	34,200 [10.0]	13,300 [3.9]	11.75	13.00	76	1525 [720]	
RCTA-A060		46,000 [13.5]	32,850 [9.6]	13,150 [3.9]	11.20	12.00	76	1600 [755]

① Highest sales volume tested combination required by D.O.E. test procedures.

[] Designates Metric Conversions

Performance Data @ ARI Standard Conditions—Cooling (Con't.)

Model Numbers		80°F [26.5°C] DB/67°F [19.5°C] WB Indoor Air 95°F [35°C] DB Outdoor Air					Sound Rating dB	Indoor CFM [L/s]
Outdoor Unit UAND-	Indoor Coil and/or Air Handler	Total Capacity BTU/H [kW]	Net Sensible BTU/H [kW]	Net Latent BTU/H [kW]	EER	SEER		
060C*Z/ D*Z/J*Z/Y*Z	RCFA-H*6024A* ①	57,500 [16.8]	39,700 [11.6]	17,800 [5.2]	11.35	13.00	76	1675 [790]
	RCBA-60**+RXCT-BCK	54,500 [16.0]	36,650 [10.7]	17,850 [5.2]	10.50	12.00	76	2000 [944]
	UBHC-24 (RCBA-60**+RXCT-BCK)	53,500 [15.7]	35,150 [10.3]	18,350 [5.4]	10.40	11.50	76	1800 [849]
	UBHK-25 (RCBA-60**+RXCT-BCK)	55,500 [16.3]	37,600 [11.0]	17,900 [5.2]	11.30	13.00	76	2000 [944]
	RCFA-A*6024B*	57,500 [16.8]	39,700 [11.6]	17,800 [5.2]	11.35	13.00	76	1675 [790]
	RCHJ-60A1	54,500 [16.0]	36,650 [10.7]	17,850 [5.2]	10.50	12.00	76	2000 [944]
	25AHBA60HM (RCHJ-60A1)	54,500 [16.0]	36,000 [10.5]	18,500 [5.4]	11.35	13.00	76	1800 [849]
	UBHK-25 (RCHJ-60A1)	55,500 [16.3]	37,600 [11.0]	17,900 [5.2]	11.30	13.00	76	2000 [944]
	UBHP-25 (RCHJ-60A1)	54,500 [16.0]	36,000 [10.5]	18,500 [5.4]	11.35	13.00	76	1800 [849]
	RCQC-6024A	56,000 [16.4]	39,700 [11.6]	16,300 [4.8]	10.80	12.00	76	2000 [944]
	RCQC-6124A	57,500 [16.8]	39,950 [11.7]	17,550 [5.1]	11.30	12.00	76	1675 [790]
	RCQC-6124A (UGFD-12?RCM?)	58,000 [17.0]	40,250 [11.8]	17,750 [5.2]	11.50	13.00	76	1650 [779]
	RCQC-6124A (UGPR-07?BRQ?)	57,500 [16.8]	40,400 [11.8]	17,100 [5.0]	11.55	13.00	76	1625 [767]
	RCQC-6124A (UGPR-12?ARM?)	57,500 [16.8]	40,500 [11.9]	17,000 [5.0]	11.60	13.00	76	1575 [743]
	24AHLA60HM (RCSA-H*6024A*)	59,000 [17.3]	40,700 [11.9]	18,300 [5.4]	12.10	13.50	76	1800 [849]
	UHKA-HM6024 (RCSA-H*6024A*)	59,000 [17.3]	40,700 [11.9]	18,300 [5.4]	12.05	13.50	76	1800 [849]
	UHLA-HM6024 (RCSA-H*6024A*)	59,000 [17.3]	40,700 [11.9]	18,300 [5.4]	12.10	13.50	76	1800 [849]
	UHSA-HM6024 (RCSA-H*6024A*)	58,000 [17.0]	40,350 [11.8]	17,650 [5.2]	10.95	12.00	76	1750 [826]
RCTA-A060	53,500 [15.7]	37,100 [10.9]	16,400 [4.8]	10.40	12.00	76	2000 [944]	

① Highest sales volume tested combination required by D.O.E. test procedures.

[] Designates Metric Conversions

Electrical and Physical Data

Model Number UAND-	ELECTRICAL							PHYSICAL						
	Phase Frequency (Hz) Voltage (Volts)	Compressor		Fan Motor Full Load Amperes (FLA)	Minimum Circuit Ampacity Amperes	Fuse or HACR Circuit Breaker		Outdoor Coil			Refrig. Per Circuit Oz. [g]	Weight		
		Rated Load Amperes (RLA)	Locked Rotor Amperes (LRA)			Minimum Amperes	Maximum Amperes	Face Area Sq. Ft. [m ²]	No. Rows	CFM [L/s]		Net Lbs. [kg]	Shipping Lbs. [kg]	
018J*Z	1-60-208/230	7.7/7.7	40.3	0.6	11/11	15/15	15/15	9.07 [0.84]	1	1640 [774]	68 [1928]	135 [61.2]	145 [65.8]	
024J*Z	1-60-208/230	10.4/10.4	54.0	0.6	14/14	20/20	20/20	11 [1.02]	1	1900 [897]	76 [2155]	145 [65.8]	155 [70.3]	
030J*Z	1-60-208/230	14.1/14.1	72.5	0.8	19/19	25/25	30/30	12.94 [1.20]	1	2520 [1189]	88 [2495]	160 [72.6]	170 [77.1]	
036C*Z	3-60-208/230	9.6/9.6	88.0	1.2	14/14	20/20	20/20	17.26 [1.60]	1	3290 [1553]	116 [3289]	180 [81.6]	190 [86.2]	
036D*Z	3-60-460	5.8	38.0	0.6	8	15	15	17.26 [1.60]	1	3290 [1553]	116 [3289]	180 [81.6]	190 [86.2]	
036J*Z	1-60-208/230	14.4/14.4	77.0	1.2	20/20	25/25	30/30	17.26 [1.60]	1	3290 [1553]	116 [3289]	180 [81.6]	190 [86.2]	
042C*Z	3-60-208/230	12.2/12.2	88.0	1.2	17/17	20/20	25/25	17.26 [1.60]	1	3290 [1553]	136 [3856]	195 [88.5]	205 [93.0]	
042D*Z	3-60-460	5.8	44.0	0.6	8	15	15	17.26 [1.60]	1	3290 [1553]	136 [3856]	195 [88.5]	205 [93.0]	
042J*Z	1-60-208/230	19.2/19.2	105.0	1.2	26/26	30/30	40/40	17.26 [1.60]	1	3290 [1553]	136 [3856]	195 [88.5]	205 [93.0]	
048C*Z	3-60-208/230	12.2/12.2	83.1	1.2	17/17	20/20	25/25	23.01 [2.14]	1	3500 [1652]	146 [4139]	225 [102.1]	235 [106.6]	
048D*Z	3-60-460	6.1	41.0	0.6	9	15	15	23.01 [2.14]	1	3500 [1652]	146 [4139]	225 [102.1]	235 [106.6]	
048J*Z	1-60-208/230	20.2/20.2	137.0	1.2	27/27	35/35	45/45	23.01 [2.14]	1	3500 [1652]	146 [4139]	225 [102.1]	235 [106.6]	
048Y*Z	3-60-575	4.8	33.0	0.5	6	15	15	23.01 [2.14]	1	3500 [1652]	146 [4139]	225 [102.1]	235 [106.6]	
060C*Z	3-60-208/230	15.4/15.4	110.0	1.2	21/21	25/25	35/35	23.01 [2.14]	1	3500 [1652]	176 [4990]	230 [104.3]	240 [108.9]	
060D*Z	3-60-460	7.1	52.0	0.6	10	15	15	23.01 [2.14]	1	3500 [1652]	176 [4990]	230 [104.3]	240 [108.9]	
060J*Z	1-60-208/230	25.3/25.3	150.0	1.2	33/33	40/40	50/50	23.01 [2.14]	1	3500 [1652]	176 [4990]	230 [104.3]	240 [108.9]	
060Y*Z	3-60-575	5.3	36.1	0.5	8	15	15	23.01 [2.14]	1	3500 [1652]	176 [4990]	230 [104.3]	240 [108.9]	

[] Designates Metric Conversions

Unit Dimensions

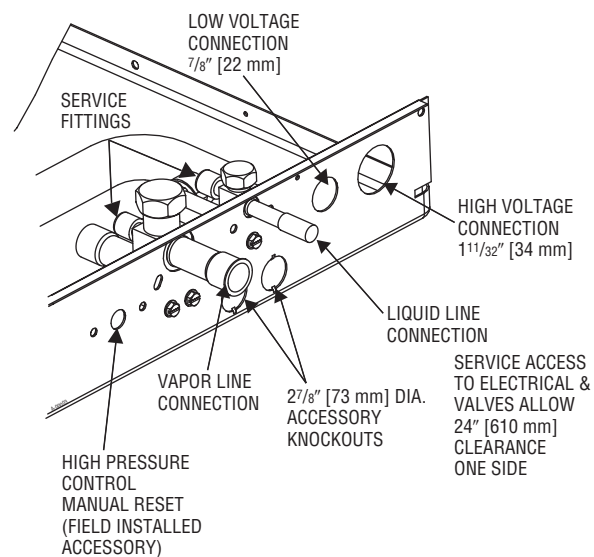
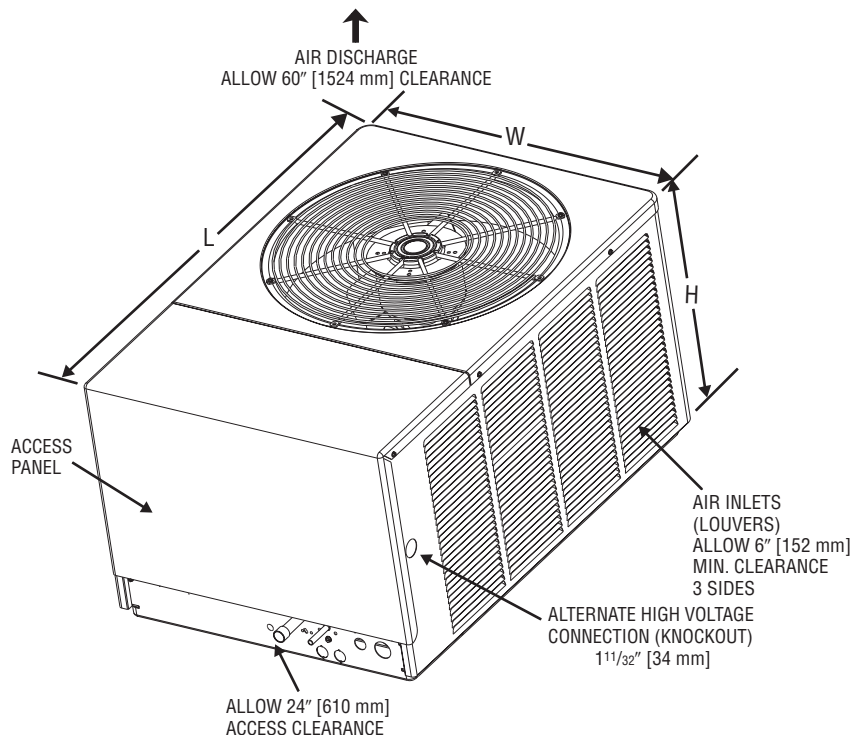

Model Number UAND-	Height "H" (Inches) [mm]	Length "L" (Inches) [mm]	Width "W" (Inches) [mm]
018	19 [482]	33 ¹ / ₂ [851]	23 ³ / ₄ [603]
024	19 [482]	39 [990]	27 ⁵ / ₈ [702]
030	19 [482]	43 [1092]	31 ¹ / ₂ [800]
036/042	25 [635]	43 [1092]	31 ¹ / ₂ [800]
048/060	33 [838]	43 [1092]	31 ¹ / ₂ [800]

[] Designates Metric Conversions

BEFORE PURCHASING THIS APPLIANCE, READ IMPORTANT ENERGY COST AND EFFICIENCY INFORMATION AVAILABLE FROM YOUR RETAILER.

GENERAL TERMS OF LIMITED WARRANTY

Ruud will furnish a replacement for any part of this product which fails in normal use and service within the applicable period stated, in accordance with the terms of the limited warranty.

For Complete Details of the Limited Warranty, Including Applicable Terms and Conditions, See Your Local Installer or Contact the Manufacturer for a Copy.

Condenser Coil leaks caused by	
factory defects	Five (5) Years
Compressor	
JAZ	Ten (10) Years
CAZ, DAZ, YAZ	Five (5) Years
All Other Parts	
JAZ	Five (5) Years
CAZ, DAZ, YAZ.....	One Year

Condensing Unit Refrigerant Line Size Information

System Capacity Model	Liquid Line Connection Size (Inch I.D.)	Line Size (Inch O.D.) [mm]	Liquid Line Size — Outdoor Unit Above Indoor Coil (Cooling Only — Does not apply to Heat Pumps)						Liquid Line Size Cooling Only With Outdoor Unit Below Indoor Coil					
			Total Equivalent Length—Feet [m]						Total Equivalent Length—Feet [m]					
			25 [7.62]	50 [15.24]	75 [22.86]	100 [30.48]	125 [38.10]	150 [45.72]	25 [7.62]	50 [15.24]	75 [22.86]	100 [30.48]	125 [38.10]	150 [45.72]
			Minimum Vertical Separation—Feet [m]						Maximum Vertical Separation—Feet [m]					
1 1/2 Ton	3/8"	1/4 [6.35]	0	0	5 [1.52]	18 [5.49]	31 [9.45]	44 [13.41]	21 [6.40]	8 [2.44]	N/A	N/A	N/A	N/A
		5/16 [7.94]	0	0	0	0	0	0	25 [7.62]	27 [8.23]	24 [7.32]	21 [6.40]	17 [5.18]	14 [4.27]
		3/8* [9.53]	0	0	0	0	0	0	25 [7.62]	40 [12.19]	39 [11.89]	38 [11.58]	37 [11.28]	35 [10.67]
2 Ton	3/8"	1/4 [6.35]	0	5 [1.52]	27 [8.23]	48 [14.63]	69 [21.03]	91 [27.74]	16 [4.88]	N/A	N/A	N/A	N/A	N/A
		5/16 [7.94]	0	0	0	0	0	0	25 [7.62]	26 [7.92]	21 [6.40]	15 [4.57]	10 [3.05]	5 [1.52]
		3/8* [9.53]	0	0	0	0	0	0	25 [7.62]	38 [11.58]	36 [10.97]	35 [10.67]	33 [10.06]	31 [9.45]
2 1/2 Ton	3/8"	1/4 [6.35]	0	34 [10.36]	69 [21.03]	N/A	N/A	N/A	0	N/A	N/A	N/A	N/A	N/A
		5/16 [7.94]	0	0	0	0	9 [2.74]	18 [5.49]	25 [7.62]	17 [5.18]	8 [2.44]	0	N/A	N/A
		3/8* [9.53]	0	0	0	0	0	0	25 [7.62]	37 [11.28]	34 [10.36]	31 [9.45]	29 [8.84]	26 [7.92]
3 Ton	3/8"	5/16 [7.94]	0	0	0	6 [1.83]	17 [5.18]	28 [8.53]	25 [7.62]	15 [4.57]	4 [1.22]	N/A	N/A	N/A
		3/8* [9.53]	0	0	0	0	0	0	25 [7.62]	30 [9.14]	26 [7.92]	23 [7.01]	19 [5.79]	16 [4.88]
		5/16 [7.94]	0	0	0	13 [3.96]	28 [8.53]	43 [13.11]	25 [7.62]	17 [5.18]	2 [0.61]	N/A	N/A	N/A
3 1/2 Ton	3/8"	3/8* [9.53]	0	0	0	0	0	0	25 [7.62]	37 [11.28]	32 [9.75]	28 [8.53]	23 [7.01]	18 [5.49]
		1/2 [12.7]	0	0	0	0	0	0	25 [7.62]	43 [13.11]	42 [12.80]	40 [12.19]	39 [11.89]	38 [11.58]
		3/8* [9.53]	0	0	0	0	0	9 [2.74]	25 [7.62]	25 [7.62]	17 [5.18]	8 [2.44]	0	N/A
5 Ton	3/8"	1/2 [12.7]	0	0	0	0	0	0	25 [7.62]	39 [11.89]	37 [11.28]	36 [10.97]	34 [10.36]	32 [9.75]
		3/8* [9.53]	0	0	0	0	0	0	25 [7.62]	39 [11.89]	37 [11.28]	36 [10.97]	34 [10.36]	32 [9.75]

*Standard line size
N/A Application not recommended.

Suction Line Length/Size versus Capacity Multiplier (R-22)									
Unit Size		1 1/2 Ton	2 Ton	2 1/2 Ton	3 Ton	3 1/2 Ton	4 Ton	5 ton	
Unit Suction Line Connection Size		3/4" [19.05 mm] I.D. Sweat			7/8" [22.23 mm] I.D. Sweat			7/8" [22.23 mm] I.D. Sweat	
Suction Line Run—Feet [m]		5/8" [15.88 mm] O.D. Optional 3/4" [19.05 mm] O.D. Standard*	5/8" [15.88 mm] O.D. Optional 3/4" [19.05 mm] O.D. Standard* 7/8" [22.23 mm] O.D. Optional	3/4" [19.05 mm] O.D. Optional 7/8" [22.23 mm] O.D. Standard*	3/4" [19.05 mm] O.D. Optional 7/8" [22.23 mm] O.D. Standard* 1 1/8" [28.58 mm] O.D. Optional	7/8" [22.23 mm] O.D. Optional 1 1/8" [28.58 mm] O.D. Standard*	1 1/8" [28.58 mm] O.D. Standard*		
25' [7.62]	Optional	0.99	0.99	0.98	0.99	0.99	0.99	0.99	0.99
	Standard	1.00	1.00	1.00	1.00	1.00	1.00	1.00	1.00
	Optional	—	1.00	1.00	—	1.00	—	—	—
50' [15.24]	Optional	0.97	0.96	0.96	0.98	0.97	0.98	0.97	0.97
	Standard	0.99	0.99	0.98	0.99	0.98	0.99	0.99	0.99
	Optional	—	0.99	0.99	—	1.00	—	—	—
100' [30.48]	Optional	0.94	0.92	0.94	0.95	0.93	0.95	0.95	0.95
	Standard	0.96	0.96	0.96	0.96	0.96	0.98	0.98	0.98
	Optional	—	0.97	0.97	—	0.98	—	—	—
150' [45.72]	Optional	0.90	0.89	0.92	0.93	0.92	0.93	0.93	0.93
	Standard	0.93	0.93	0.93	0.94	0.94	0.96	0.96	0.96
	Optional	—	0.95	0.95	—	0.96	—	—	—

*Standard line size
Note: Using suction line larger than shown in chart will result in poor oil return and is not recommended.

[] Designates Metric Conversions

NOTES

NOTES

Before proceeding with installation, refer to installation instructions packaged with each model, as well as complying with all Federal, State, Provincial, and Local codes, regulations, and practices.

**RUUD
AIR CONDITIONING
DIVISION**

5600 Old Greenwood Road, Fort Smith, Arkansas 72908



"In keeping with its policy of continuous progress and product improvement, Ruud reserves the right to make changes without notice."