

CONDENSING UNITS



UAPC- SERIES

14 SEER Models
With efficiencies up to 16 SEER
in certain matched systems.
Nominal Sizes 2 to 5 Tons
[7.03 kW] to [17.58 kW]



Six Models

Cooling Capacities
23,200 to 56,500 BTU/HR
[6.8 kW] to [16.6 kW]

The *Ruud Achiever Series*® High Efficiency UAPC- Condensing Unit was designed with performance in mind. These units offer comfort, energy conservation and dependability for single, multi-family and light commercial applications.

The *Ruud Achiever Series*® UAPC- Condensing Units are the result of an ongoing development program for improved efficiencies. With system SEER's ranging to 16.00, these units continue a tradition of high efficiency.

- Attractive, louvered wrap-around jacket protects the coil from yard hazards and weather extremes. Top grille is steel reinforced for extra strength. Cabinet is powder painted for all-weather protection.
- Air is discharged upward away from bushes and shrubs. The discharge pattern of the top grille provides minimum air restriction, resulting in quiet fan operation.
- Exclusive Combination Grille/Motor Mount secures the motor to the underside of the discharge grille. The grille protects the motor windings and bearings from rain and snow.
- All controls are accessible by removing one service panel. Removable top grille provides access to the condenser fan motor and condenser coil.
- Single speed motor designed for low speed, quiet, energy-saving operation.
- All models meet or exceed a 1000-hour salt spray test per ASTM B117 Standard Practice for Operating Salt Spray Testing Apparatus.

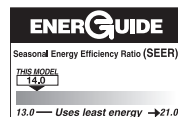



All controls and compressor are accessible for servicing by removal of the service panel.

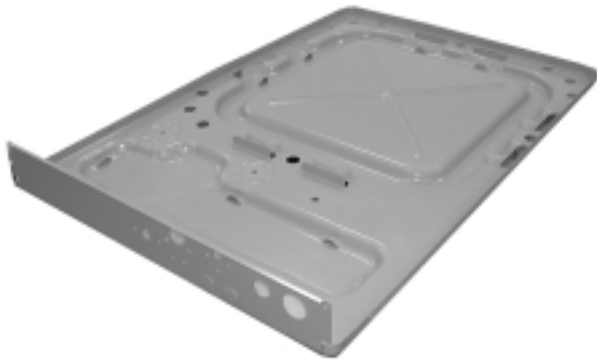

Drawn Painted Base Pan.

Engineering Features

UAPC- Series Condensing Units

1. Scroll compressor is hermetically sealed and incorporates internal high temperature motor overload protection, and durable insulation on the motor windings. It is externally mounted on rubber grommets to reduce vibration and noise.
2. Compressors have an internal pressure relief assembly to protect against excessive pressure differential.
3. All refrigerant connections are on the exterior of the unit, located close to the ground for neat appearing installations.
4. Cabinet is constructed of powder painted galvanized steel. The full wrap-around louvered grille protects the coil from damage.
5. Copper Tube—Aluminum Fin coils are used on all models.
6. The control box is located in the top corner of the cabinet providing for easy access through a service panel.
7. Service valves are standard on all models.
8. Power and control wiring are kept separate.
9. Every unit is factory charged and tested.
10. Separate compressor compartment for easy service access.
11. Drawn, painted base pan for extra corrosion resistance and sound reduction.
12. **UAPC** has a **10 year compressor limited warranty**. The **UAPC-***JAZ models feature factory-installed low & high pressure controls, hard start components and liquid line filter drier**.

Field Installed Accessories

- **Low Ambient Control**—Cycles outdoor fan to maintain adequate condensing pressures assuring liquid refrigerant flow to the coil. Allows indoor cooling with outdoor temperatures down to 0°F [-17.8°C]. (Model No. RXAD-A04)
It is recommended that this control be installed in units to be operated at outdoor ambient temperatures under 70°F [21°C].
- **Compressor Time Delay Control**—Compressor will remain off for five minutes after power or thermostat interruption, allowing system pressures to equalize. (Model No. RXMD-B01)
- **Hard Start Components**—Offer additional starting torque to cover a wide range of voltage and pressure variations. Available through PROSTOCK®

SCROLL COMPRESSOR

The scroll compressor is the key to efficiency for this Ruud model. It's the latest in high-efficiency compressor technology. The advanced scroll compressor offers low noise and vibration characteristics and features tolerance to liquid refrigerant and system contamination. The scroll compressor also has low start torque, eliminating start problems in the field. And its unique design enables the UAPC- condensing unit to perform efficiently, quietly and reliably.



Model Number Identification

<u>U</u>	<u>A</u>	<u>P</u>	<u>C</u>	—	<u>024</u>	<u>J</u>	<u>A</u>	<u>Z</u>
RUUD	REMOTE CONDENSING UNIT	HI-EFFICIENCY (STANDARD)	DESIGN SERIES		COOLING CAPACITY	ELECTRICAL DESIGNATION	VARIATIONS	COOLING CONNECTION FITTING
			C = THIRD DESIGN		024 = 24,000 BTU/HR [7.03 kW] 030 = 30,000 BTU/HR [8.79 kW] 036 = 36,000 BTU/HR [10.55 kW] 042 = 42,000 BTU/HR [12.31 kW] 048 = 48,000 BTU/HR [14.07 kW] 060 = 60,000 BTU/HR [17.58 kW]	J = 208/230V-1-60	A = STANDARD	Z = SWEAT W/SCROLL

Performance Data @ ARI Standard Conditions—Cooling

Model Numbers		80°F [26.5°C] DB/67°F [19.5°C] WB Indoor Air 95°F [35°C] DB Outdoor Air					Sound Rating dB	Indoor CFM [L/s]
Outdoor Unit UAPC-	Indoor Coil and/or Air Handler	Total Capacity BTU/H [kW]	Net Sensible BTU/H [kW]	Net Latent BTU/H [kW]	EER	SEER		
024JAZ	RCQC-3617A+RXMD-C04 ①	24,800 [7.3]	18,100 [5.3]	6,700 [2.0]	11.60	14.40	74	800 [378]
	RCFA-A*2414A*	24,600 [7.2]	17,250 [5.1]	7,350 [2.2]	12.25	14.00	74	800 [378]
	RCFA-A*2417A*	24,600 [7.2]	17,250 [5.1]	7,350 [2.2]	12.25	14.00	74	800 [378]
	RCFA-A*2417A* (UGFD-06?MCK?)	25,400 [7.4]	18,350 [5.4]	7,050 [2.1]	13.15	15.00	74	800 [378]
	RCFA-A*2417A* (UGFD-07?MCK?)	25,600 [7.5]	18,400 [5.4]	7,200 [2.1]	13.25	15.00	74	800 [378]
	RCFA-A*2417A* (UGGD-06?MCK?)	25,600 [7.5]	18,450 [5.4]	7,150 [2.1]	13.50	15.00	74	800 [378]
	RCFA-A*2417A* (UGGD-07?MCK?)	25,600 [7.5]	18,400 [5.4]	7,200 [2.1]	13.40	15.00	74	800 [378]
	RCFA-A*2417A* (UGJD-06?MCK?)	25,600 [7.5]	18,450 [5.4]	7,150 [2.1]	13.50	15.00	74	800 [378]
	RCFA-A*2417A* (UGJD-07?MCK?)	25,600 [7.5]	18,400 [5.4]	7,200 [2.1]	13.40	15.00	74	800 [378]
	RCFA-A*2417A* (UGLR-07?AMK?)	25,600 [7.5]	18,500 [5.4]	7,100 [2.1]	13.70	15.00	74	800 [378]
	RCFA-A*2417A* (UGPR-05?BMK?)	25,600 [7.5]	18,400 [5.4]	7,200 [2.1]	13.30	15.00	74	775 [366]
	RCFA-A*2417A* (UGPR-07?AMK?)	25,600 [7.5]	18,450 [5.4]	7,150 [2.1]	13.60	15.00	74	800 [378]
	RCFA-H*2414A*	24,600 [7.2]	17,250 [5.1]	7,350 [2.2]	12.25	14.00	74	800 [378]
	RCFA-H*2417A*	24,600 [7.2]	17,250 [5.1]	7,350 [2.2]	12.25	14.00	74	800 [378]
	RCFA-H*2417A* (UGFD-06?MCK?)	25,400 [7.4]	18,350 [5.4]	7,050 [2.1]	13.15	15.00	74	800 [378]
	RCFA-H*2417A* (UGFD-07?MCK?)	25,600 [7.5]	18,400 [5.4]	7,200 [2.1]	13.25	15.00	74	800 [378]
	RCFA-H*2417A* (UGGD-06?MCK?)	25,600 [7.5]	18,450 [5.4]	7,150 [2.1]	13.50	15.00	74	800 [378]
	RCFA-H*2417A* (UGGD-07?MCK?)	25,600 [7.5]	18,400 [5.4]	7,200 [2.1]	13.40	15.00	74	800 [378]
	RCFA-H*2417A* (UGJD-06?MCK?)	25,600 [7.5]	18,450 [5.4]	7,150 [2.1]	13.50	15.00	74	800 [378]
	RCFA-H*2417A* (UGJD-07?MCK?)	25,600 [7.5]	18,400 [5.4]	7,200 [2.1]	13.40	15.00	74	800 [378]
	RCFA-H*2417A* (UGLR-07?AMK?)	25,600 [7.5]	18,500 [5.4]	7,100 [2.1]	13.70	15.00	74	800 [378]
	RCFA-H*2417A* (UGPR-05?BMK?)	25,600 [7.5]	18,400 [5.4]	7,200 [2.1]	13.30	15.00	74	775 [366]
	RCFA-H*2417A* (UGPR-07?AMK?)	25,600 [7.5]	18,450 [5.4]	7,150 [2.1]	13.60	15.00	74	800 [378]
	17AHBA24HM (RCHJ-24A1)	23,600 [6.9]	15,500 [4.5]	8,100 [2.4]	12.50	14.00	74	800 [378]
	UBHP-17 (RCHJ-24A1)	23,600 [6.9]	15,500 [4.5]	8,100 [2.4]	12.50	14.00	74	800 [378]
	UBHK-17 (RCHJ-24A2)	24,000 [7.0]	17,700 [5.2]	6,300 [1.8]	12.30	15.00	74	800 [378]
	RCHJ-24A2 (UGFD-06?MCK?)	23,800 [7.0]	17,500 [5.1]	6,300 [1.8]	12.00	14.65	74	800 [378]
	RCHJ-24A2 (UGFD-07?MCK?)	23,800 [7.0]	17,500 [5.1]	6,300 [1.8]	12.10	14.75	74	800 [378]
	RCHJ-24A2 (UGLR-07?AMK?)	24,000 [7.0]	17,700 [5.2]	6,300 [1.8]	12.60	15.00	74	800 [378]
	RCHJ-24A2 (UGPR-05?BMK?)	24,000 [7.0]	17,700 [5.2]	6,300 [1.8]	12.50	14.50	74	800 [378]
	RCHJ-24A2 (UGPR-07?AMK?)	24,000 [7.0]	17,700 [5.2]	6,300 [1.8]	12.35	15.00	74	800 [378]
	RCHJ-24A2+RXMD-C04	23,200 [6.8]	16,900 [5.0]	6,300 [1.8]	10.90	13.45	74	800 [378]
	RCQC-2417A (UGFD-06?MCK?)	24,800 [7.3]	18,200 [5.3]	6,600 [1.9]	12.20	14.75	74	800 [378]
	RCQC-2417A (UGFD-07?MCK?)	24,800 [7.3]	18,200 [5.3]	6,600 [1.9]	12.35	14.90	74	800 [378]
	RCQC-2417A (UGPR-05?BMK?)	25,000 [7.3]	18,400 [5.4]	6,600 [1.9]	12.80	15.50	74	800 [378]
	RCQC-2417A+RXMD-C04	24,400 [7.1]	17,800 [5.2]	6,600 [1.9]	11.30	14.00	74	800 [378]
	UBHL-17 (RCQC-2417B)	25,400 [7.4]	18,300 [5.4]	7,100 [2.1]	13.50	15.50	74	800 [378]
	RCQC-3617A (UGFD-06?MCK?)	25,200 [7.4]	18,500 [5.4]	6,700 [2.0]	12.60	15.40	74	800 [378]
	RCQC-3617A (UGFD-07?MCK?)	25,400 [7.4]	18,700 [5.5]	6,700 [2.0]	12.70	15.55	74	800 [378]
	RCQC-3617A (UGPR-05?BMK?)	25,400 [7.4]	18,700 [5.5]	6,700 [2.0]	13.20	15.65	74	800 [378]
	RCQC-3621A (UGFD-06?MCK?)	25,400 [7.4]	18,700 [5.5]	6,700 [2.0]	12.70	15.50	74	800 [378]
	RCQC-3621A (UGFD-07?MCK?)	25,400 [7.4]	18,700 [5.5]	6,700 [2.0]	12.80	15.65	74	800 [378]
	RCQC-3621A (UGPR-05?BMK?)	25,600 [7.5]	18,900 [5.5]	6,700 [2.0]	13.30	15.65	74	800 [378]
	RCQC-3621A (UGPR-07?AMK?)	25,400 [7.4]	18,700 [5.5]	6,700 [2.0]	13.15	16.00	74	800 [378]
	RCQC-3621A+RXMD-C04	24,800 [7.3]	18,100 [5.3]	6,700 [2.0]	11.60	14.40	74	800 [378]
	17AHS24AU (RCSA-A*2417A*)	25,400 [7.4]	18,250 [5.3]	7,150 [2.1]	12.75	14.50	74	800 [378]
	17AHLA24HM (RCSA-H*2417A*)	25,600 [7.5]	18,500 [5.4]	7,100 [2.1]	13.95	16.00	74	775 [366]
	17AHS24HM (RCSA-H*2417A*)	25,400 [7.4]	18,250 [5.3]	7,150 [2.1]	12.75	14.50	74	800 [378]
UHKA-HM2417 (RCSA-H*2417A*)	26,000 [7.6]	18,650 [5.5]	7,350 [2.2]	13.65	15.00	74	850 [401]	
UHLA-HM2417 (RCSA-H*2417A*)	25,600 [7.5]	18,500 [5.4]	7,100 [2.1]	13.95	16.00	74	775 [366]	
UHSA-HM2417 (RCSA-H*2417A*)	25,400 [7.4]	18,250 [5.3]	7,150 [2.1]	12.75	14.50	74	800 [378]	
030JAZ	RCQC-3121A+RXMD-C04 ①	29,800 [8.7]	22,500 [6.6]	7,300 [2.1]	12.00	14.00	74	1,050 [495]
	RCFA-A*3617A*	29,000 [8.5]	20,500 [6.0]	8,500 [2.5]	12.00	14.00	74	900 [425]

NOTES: ① Highest sales volume tested combination required by D.O.E. test procedures.

[] Designates Metric Conversions

Performance Data @ ARI Standard Conditions—Cooling (cont.)

Model Numbers		80°F [26.5°C] DB/67°F [19.5°C] WB Indoor Air 95°F [35°C] DB Outdoor Air					Sound Rating dB	Indoor CFM [L/s]
Outdoor Unit UAPC-	Indoor Coil and/or Air Handler	Total Capacity BTU/H [kW]	Net Sensible BTU/H [kW]	Net Latent BTU/H [kW]	EER	SEER		
030JAZ	RCFA-A*3617A* (UGFD-06?MCK?)	30,600 [9.0]	22,850 [6.7]	7,750 [2.3]	12.40	14.50	74	1,000 [472]
	RCFA-A*3617A* (UGFD-07?MCK?)	30,800 [9.0]	22,950 [6.7]	7,850 [2.3]	12.65	14.50	74	1,000 [472]
	RCFA-A*3617A* (UGGD-06?MCK?)	30,800 [9.0]	23,000 [6.7]	7,800 [2.3]	12.75	14.50	74	1,000 [472]
	RCFA-A*3617A* (UGGD-07?MCK?)	30,800 [9.0]	22,950 [6.7]	7,850 [2.3]	12.65	14.50	74	1,025 [484]
	RCFA-A*3617A* (UGJD-06?MCK?)	30,800 [9.0]	23,000 [6.7]	7,800 [2.3]	12.75	14.50	74	1,000 [472]
	RCFA-A*3617A* (UGJD-07?MCK?)	30,800 [9.0]	22,950 [6.7]	7,850 [2.3]	12.65	14.50	74	1,025 [484]
	RCFA-A*3617A* (UGLR-07?AMK?)	30,000 [8.8]	20,800 [6.1]	9,200 [2.7]	12.85	14.50	74	1,025 [484]
	RCFA-A*3617A* (UGPR-05?BMK?)	30,800 [9.0]	22,950 [6.7]	7,850 [2.3]	12.60	14.50	74	1,000 [472]
	RCFA-A*3617A* (UGPR-07?AMK?)	29,800 [8.7]	20,800 [6.1]	9,000 [2.6]	12.75	14.50	74	1,000 [472]
	RCFA-A*3621A*	29,000 [8.5]	20,500 [6.0]	8,500 [2.5]	12.00	14.00	74	900 [425]
	RCFA-A*3621A* (UGFD-06?MCK?)	30,600 [9.0]	22,850 [6.7]	7,750 [2.3]	12.40	14.50	74	1,000 [472]
	RCFA-A*3621A* (UGFD-07?MCK?)	30,800 [9.0]	22,950 [6.7]	7,850 [2.3]	12.65	14.50	74	1,000 [472]
	RCFA-A*3621A* (UGGD-06?MCK?)	30,800 [9.0]	23,000 [6.7]	7,800 [2.3]	12.75	14.50	74	1,000 [472]
	RCFA-A*3621A* (UGGD-07?MCK?)	30,800 [9.0]	22,950 [6.7]	7,850 [2.3]	12.65	14.50	74	1,025 [484]
	RCFA-A*3621A* (UGJD-06?MCK?)	30,800 [9.0]	23,000 [6.7]	7,800 [2.3]	12.75	14.50	74	1,000 [472]
	RCFA-A*3621A* (UGJD-07?MCK?)	30,800 [9.0]	22,950 [6.7]	7,850 [2.3]	12.65	14.50	74	1,025 [484]
	RCFA-A*3621A* (UGLR-07?AMK?)	30,800 [9.0]	23,050 [6.8]	7,750 [2.3]	13.00	15.00	74	1,025 [484]
	RCFA-A*3621A* (UGLR-07?BRQ?)	30,000 [8.8]	21,000 [6.2]	9,000 [2.6]	13.15	15.00	74	1,000 [472]
	RCFA-A*3621A* (UGPR-05?BMK?)	30,800 [9.0]	22,950 [6.7]	7,850 [2.3]	12.60	14.50	74	1,000 [472]
	RCFA-A*3621A* (UGPR-07?AMK?)	30,800 [9.0]	23,050 [6.8]	7,750 [2.3]	12.95	15.00	74	1,000 [472]
	RCFA-A*3621A* (UGPR-07?BRQ?)	31,000 [9.1]	23,200 [6.8]	7,800 [2.3]	13.35	15.00	74	1,000 [472]
	RCFA-H*3617A*	29,000 [8.5]	20,500 [6.0]	8,500 [2.5]	12.00	14.00	74	900 [425]
	RCFA-H*3617A* (UGFD-06?MCK?)	30,600 [9.0]	22,850 [6.7]	7,750 [2.3]	12.40	14.50	74	1,000 [472]
	RCFA-H*3617A* (UGFD-07?MCK?)	30,800 [9.0]	22,950 [6.7]	7,850 [2.3]	12.65	14.50	74	1,000 [472]
	RCFA-H*3617A* (UGGD-06?MCK?)	30,800 [9.0]	23,000 [6.7]	7,800 [2.3]	12.75	14.50	74	1,000 [472]
	RCFA-H*3617A* (UGGD-07?MCK?)	30,800 [9.0]	22,950 [6.7]	7,850 [2.3]	12.65	14.50	74	1,025 [484]
	RCFA-H*3617A* (UGJD-06?MCK?)	30,800 [9.0]	23,000 [6.7]	7,800 [2.3]	12.75	14.50	74	1,000 [472]
	RCFA-H*3617A* (UGJD-07?MCK?)	30,800 [9.0]	22,950 [6.7]	7,850 [2.3]	12.65	14.50	74	1,025 [484]
	RCFA-H*3617A* (UGLR-07?AMK?)	30,000 [8.8]	20,800 [6.1]	9,200 [2.7]	12.85	14.50	74	1,025 [484]
	RCFA-H*3617A* (UGPR-05?BMK?)	30,800 [9.0]	22,950 [6.7]	7,850 [2.3]	12.60	14.50	74	1,000 [472]
	RCFA-H*3617A* (UGPR-07?AMK?)	29,800 [8.7]	20,800 [6.1]	9,000 [2.6]	12.75	14.50	74	1,000 [472]
	RCFA-H*3621A*	29,000 [8.5]	20,500 [6.0]	8,500 [2.5]	12.00	14.00	74	900 [425]
	RCFA-H*3621A* (UGFD-06?MCK?)	30,600 [9.0]	22,850 [6.7]	7,750 [2.3]	12.40	14.50	74	1,000 [472]
	RCFA-H*3621A* (UGFD-07?MCK?)	30,800 [9.0]	22,950 [6.7]	7,850 [2.3]	12.65	14.50	74	1,000 [472]
	RCFA-H*3621A* (UGGD-06?MCK?)	30,800 [9.0]	23,000 [6.7]	7,800 [2.3]	12.75	14.50	74	1,000 [472]
	RCFA-H*3621A* (UGGD-07?MCK?)	30,800 [9.0]	22,950 [6.7]	7,850 [2.3]	12.65	14.50	74	1,025 [484]
	RCFA-H*3621A* (UGJD-06?MCK?)	30,800 [9.0]	23,000 [6.7]	7,800 [2.3]	12.75	14.50	74	1,000 [472]
	RCFA-H*3621A* (UGJD-07?MCK?)	30,800 [9.0]	22,950 [6.7]	7,850 [2.3]	12.65	14.50	74	1,025 [484]
	RCFA-H*3621A* (UGLR-07?AMK?)	30,800 [9.0]	23,050 [6.8]	7,750 [2.3]	13.00	15.00	74	1,025 [484]
	RCFA-H*3621A* (UGLR-07?BRQ?)	30,000 [8.8]	21,000 [6.2]	9,000 [2.6]	13.15	15.00	74	1,000 [472]
	RCFA-H*3621A* (UGPR-05?BMK?)	30,800 [9.0]	22,950 [6.7]	7,850 [2.3]	12.60	14.50	74	1,000 [472]
	RCFA-H*3621A* (UGPR-07?AMK?)	30,800 [9.0]	23,050 [6.8]	7,750 [2.3]	12.95	15.00	74	1,000 [472]
	RCFA-H*3621A* (UGPR-07?BRQ?)	31,000 [9.1]	23,200 [6.8]	7,800 [2.3]	13.35	15.00	74	1,000 [472]
	21AHBA36HM (RCHJ-36A1)	29,200 [8.6]	20,650 [6.1]	8,550 [2.5]	12.70	14.00	74	1,000 [472]
	UBHK-21 (RCHJ-36A1)	29,400 [8.6]	22,400 [6.6]	7,000 [2.1]	12.95	14.70	74	1,000 [472]
UBHP-21 (RCHJ-36A1)	29,200 [8.6]	20,650 [6.1]	8,550 [2.5]	12.70	14.00	74	1,000 [472]	
RCHJ-36A1 (UGFD-06?MCK?)	29,000 [8.5]	22,000 [6.4]	7,000 [2.1]	12.15	13.70	74	1,000 [472]	
RCHJ-36A1 (UGFD-07?MCK?)	29,000 [8.5]	22,000 [6.4]	7,000 [2.1]	12.25	13.85	74	1,000 [472]	
RCHJ-36A1 (UGLR-07?AMK?)	29,400 [8.6]	22,400 [6.6]	7,000 [2.1]	12.85	14.20	74	1,000 [472]	
RCHJ-36A1 (UGLR-07?BRQ?)	29,000 [8.5]	22,000 [6.4]	7,000 [2.1]	12.25	14.50	74	1,000 [472]	
RCHJ-36A1 (UGPR-05?BMK?)	29,400 [8.6]	22,400 [6.6]	7,000 [2.1]	12.85	13.75	74	1,000 [472]	
RCHJ-36A1 (UGPR-07?AMK?)	29,200 [8.6]	22,200 [6.5]	7,000 [2.1]	12.65	14.00	74	1,000 [472]	
RCHJ-36A1 (UGPR-07?BRQ?)	29,200 [8.6]	22,200 [6.5]	7,000 [2.1]	12.65	14.00	74	1,000 [472]	

NOTES: ① Highest sales volume tested combination required by D.O.E. test procedures.

[] Designates Metric Conversions

Performance Data @ ARI Standard Conditions—Cooling (cont.)

Model Numbers		80°F [26.5°C] DB/67°F [19.5°C] WB Indoor Air 95°F [35°C] DB Outdoor Air					Sound Rating dB	Indoor CFM [L/s]
Outdoor Unit UAPC-	Indoor Coil and/or Air Handler	Total Capacity BTU/H [kW]	Net Sensible BTU/H [kW]	Net Latent BTU/H [kW]	EER	SEER		
030JAZ	RCHJ-36A1+RXMD-C04	28,600 [8.4]	21,600 [6.3]	7,000 [2.1]	11.30	13.05	74	1,050 [495]
	UBHL-21 (RCQC-3021B)	30,400 [8.9]	22,400 [6.6]	8,000 [2.3]	13.20	15.40	74	1,000 [472]
	RCQC-3121A (UGFD-06?MCK?)	30,200 [8.8]	22,900 [6.7]	7,300 [2.1]	12.60	14.70	74	1,000 [472]
	RCQC-3121A (UGFD-07?MCK?)	30,200 [8.8]	22,900 [6.7]	7,300 [2.1]	12.75	14.90	74	1,000 [472]
	RCQC-3121A (UGPR-05?BMK?)	30,600 [9.0]	23,300 [6.8]	7,300 [2.1]	13.35	15.50	74	1,000 [472]
	RCQC-3121A (UGPR-07?AMK?)	30,400 [8.9]	23,100 [6.8]	7,300 [2.1]	13.10	15.00	74	1,000 [472]
	RCQC-3121A (UGPR-07?BRQ?)	30,400 [8.9]	23,100 [6.8]	7,300 [2.1]	13.10	15.00	74	1,000 [472]
	RCQC-3124A (UGPR-07?AMK?)	30,600 [9.0]	23,300 [6.8]	7,300 [2.1]	13.20	15.00	74	1,000 [472]
	RCQC-3124A (UGPR-07?BRQ?)	30,600 [9.0]	23,300 [6.8]	7,300 [2.1]	13.20	15.00	74	1,000 [472]
	RCQC-3124A+RXMD-C04	29,800 [8.7]	22,500 [6.6]	7,300 [2.1]	12.00	14.00	74	1,050 [495]
	RCQC-3617A (UGFD-06?MCK?)	29,400 [8.6]	22,300 [6.5]	7,100 [2.1]	12.05	13.60	74	1,000 [472]
	RCQC-3617A (UGFD-07?MCK?)	29,400 [8.6]	22,300 [6.5]	7,100 [2.1]	12.20	13.80	74	1,000 [472]
	RCQC-3617A (UGPR-05?BMK?)	29,800 [8.7]	22,700 [6.7]	7,100 [2.1]	12.80	14.50	74	1,000 [472]
	RCQC-3617A+RXMD-C04	29,000 [8.5]	21,900 [6.4]	7,100 [2.1]	11.50	13.25	74	1,050 [495]
	RCQC-3621A (UGFD-06?MCK?)	29,400 [8.6]	22,300 [6.5]	7,100 [2.1]	12.15	13.70	74	1,000 [472]
	RCQC-3621A (UGFD-07?MCK?)	29,400 [8.6]	22,300 [6.5]	7,100 [2.1]	12.30	13.90	74	1,000 [472]
	RCQC-3621A (UGPR-05?BMK?)	29,800 [8.7]	22,700 [6.7]	7,100 [2.1]	12.95	14.50	74	1,000 [472]
	RCQC-3621A (UGPR-07?AMK?)	29,800 [8.7]	22,700 [6.7]	7,100 [2.1]	12.75	14.00	74	1,000 [472]
	RCQC-3621A (UGPR-07?BRQ?)	29,800 [8.7]	22,700 [6.7]	7,100 [2.1]	12.75	14.00	74	1,000 [472]
	RCQC-3621A+RXMD-C04	29,000 [8.5]	21,900 [6.4]	7,100 [2.1]	11.50	13.25	74	1,050 [495]
17AHS30AU (RCSA-A*3617A*)	30,400 [8.9]	22,700 [6.7]	7,700 [2.3]	12.55	14.50	74	950 [448]	
17AHL36HM (RCSA-H*3617A*)	31,000 [9.1]	23,200 [6.8]	7,800 [2.3]	13.35	15.00	74	1,000 [472]	
17AHS30HM (RCSA-H*3617A*)	30,400 [8.9]	22,700 [6.7]	7,700 [2.3]	12.55	14.50	74	950 [448]	
UHKA-HM3617 (RCSA-H*3617A*)	31,000 [9.1]	23,150 [6.8]	7,850 [2.3]	13.20	15.00	74	1,025 [484]	
UHLA-HM3617 (RCSA-H*3617A*)	31,000 [9.1]	23,200 [6.8]	7,800 [2.3]	13.35	15.00	74	1,000 [472]	
UHSA-HM3017 (RCSA-H*3617A*)	30,400 [8.9]	22,700 [6.7]	7,700 [2.3]	12.55	14.50	74	950 [448]	
036JAZ	RCQC-4821A+RXMD-C04 ①	35,200 [10.3]	26,000 [7.6]	9,200 [2.7]	12.25	14.05	76	1,250 [590]
	RCFA-A*3617A*	34,600 [10.1]	24,750 [7.3]	9,850 [2.9]	11.85	13.50	76	1,100 [519]
	RCFA-A*3617A* (UGLR-07?AMK?)	34,800 [10.2]	24,550 [7.2]	10,250 [3.0]	12.25	14.00	76	1,200 [566]
	RCFA-A*3617A* (UGPR-07?AMK?)	34,800 [10.2]	24,550 [7.2]	10,250 [3.0]	12.20	14.00	76	1,200 [566]
	RCFA-A*3621A*	34,600 [10.1]	24,750 [7.3]	9,850 [2.9]	11.85	13.50	76	1,100 [519]
	RCFA-A*3621A* (UGFD-09?ZCM?)	34,800 [10.2]	25,750 [7.5]	9,050 [2.7]	12.75	14.50	76	1,150 [543]
	RCFA-A*3621A* (UGFD-10?ZCM?)	35,000 [10.3]	25,600 [7.5]	9,400 [2.8]	12.65	14.00	76	1,175 [554]
	RCFA-A*3621A* (UGGD-09?ZCM?)	35,000 [10.3]	25,700 [7.5]	9,300 [2.7]	12.80	14.50	76	1,175 [554]
	RCFA-A*3621A* (UGGD-10?ZCM?)	35,000 [10.3]	25,750 [7.5]	9,250 [2.7]	12.85	14.50	76	1,175 [554]
	RCFA-A*3621A* (UGJD-09?ZCM?)	35,000 [10.3]	25,700 [7.5]	9,300 [2.7]	12.80	14.50	76	1,175 [554]
	RCFA-A*3621A* (UGJD-10?ZCM?)	35,000 [10.3]	25,750 [7.5]	9,250 [2.7]	12.85	14.50	76	1,175 [554]
	RCFA-A*3621A* (UGLR-07?AMK?)	34,800 [10.2]	25,550 [7.5]	9,250 [2.7]	12.50	14.00	76	1,200 [566]
	RCFA-A*3621A* (UGLR-07?BRQ?)	35,200 [10.3]	25,800 [7.6]	9,400 [2.8]	12.90	15.00	76	1,225 [578]
	RCFA-A*3621A* (UGLR-10?BRM?)	35,200 [10.3]	25,850 [7.6]	9,350 [2.7]	13.00	14.50	76	1,200 [566]
	RCFA-A*3621A* (UGPR-07?AMK?)	34,800 [10.2]	25,500 [7.5]	9,300 [2.7]	12.45	14.00	76	1,200 [566]
	RCFA-A*3621A* (UGPR-07?BRQ?)	35,200 [10.3]	25,850 [7.6]	9,350 [2.7]	13.00	14.50	76	1,200 [566]
	RCFA-A*3621A* (UGPR-10?BRM?)	35,000 [10.3]	25,700 [7.5]	9,300 [2.7]	12.75	14.50	76	1,225 [578]
	RCFA-A*4821A*	35,400 [10.4]	25,300 [7.4]	10,100 [3.0]	12.35	14.00	76	1,200 [566]
	RCFA-A*4821A* (UGFD-09?ZCM?)	35,800 [10.5]	25,850 [7.6]	9,950 [2.9]	13.25	14.35	76	1,150 [543]
	RCFA-A*4821A* (UGFD-10?ZCM?)	35,800 [10.5]	25,750 [7.5]	10,050 [2.9]	13.10	14.50	76	1,175 [554]
	RCFA-A*4821A* (UGGD-09?ZCM?)	36,000 [10.5]	25,850 [7.6]	10,150 [3.0]	13.30	15.00	76	1,175 [554]
	RCFA-A*4821A* (UGGD-10?ZCM?)	36,000 [10.5]	25,850 [7.6]	10,150 [3.0]	13.30	15.00	76	1,175 [554]
	RCFA-A*4821A* (UGJD-09?ZCM?)	36,000 [10.5]	25,850 [7.6]	10,150 [3.0]	13.30	15.00	76	1,175 [554]
	RCFA-A*4821A* (UGJD-10?ZCM?)	36,000 [10.5]	25,850 [7.6]	10,150 [3.0]	13.30	15.00	76	1,175 [554]
	RCFA-A*4821A* (UGLR-07?BRQ?)	36,000 [10.5]	25,900 [7.6]	10,100 [3.0]	13.40	15.00	76	1,225 [578]
	RCFA-A*4821A* (UGLR-10?BRM?)	36,400 [10.7]	25,000 [7.3]	11,400 [3.3]	13.45	15.00	76	1,200 [566]
RCFA-A*4821A* (UGPR-07?AMK?)	35,800 [10.5]	25,600 [7.5]	10,200 [3.0]	12.90	14.50	76	1,200 [566]	

NOTES: ① Highest sales volume tested combination required by D.O.E. test procedures.

[] Designates Metric Conversions

Performance Data @ ARI Standard Conditions—Cooling (cont.)

Model Numbers		80°F [26.5°C] DB/67°F [19.5°C] WB Indoor Air 95°F [35°C] DB Outdoor Air					Sound Rating dB	Indoor CFM [L/s]
Outdoor Unit UAPC-	Indoor Coil and/or Air Handler	Total Capacity BTU/H [kW]	Net Sensible BTU/H [kW]	Net Latent BTU/H [kW]	EER	SEER		
036JAZ	RCFA-A*4821A* (UGPR-07?BRQ?)	36,000 [10.5]	25,950 [7.6]	10,050 [2.9]	13.50	15.00	76	1,200 [566]
	RCFA-A*4821A* (UGPR-10?BRM?)	36,000 [10.5]	25,800 [7.6]	10,200 [3.0]	13.30	15.00	76	1,225 [578]
	RCFA-A*4824A*	35,400 [10.4]	25,300 [7.4]	10,100 [3.0]	12.55	14.00	76	1,200 [566]
	RCFA-A*4824A* (UGFD-09?ZCM?)	35,800 [10.5]	25,850 [7.6]	9,950 [2.9]	13.25	14.35	76	1,150 [543]
	RCFA-A*4824A* (UGFD-10?ZCM?)	35,800 [10.5]	25,750 [7.5]	10,050 [2.9]	13.15	15.00	76	1,175 [554]
	RCFA-A*4824A* (UGFD-12?RCM?)	36,000 [10.5]	25,800 [7.6]	10,200 [3.0]	13.25	15.00	76	1,225 [578]
	RCFA-A*4824A* (UGGD-09?ZCM?)	36,000 [10.5]	25,850 [7.6]	10,150 [3.0]	13.30	15.00	76	1,175 [554]
	RCFA-A*4824A* (UGGD-10?ZCM?)	36,000 [10.5]	25,850 [7.6]	10,150 [3.0]	13.35	15.00	76	1,175 [554]
	RCFA-A*4824A* (UGGD-12?RCM?)	36,000 [10.5]	25,900 [7.6]	10,100 [3.0]	13.40	15.00	76	1,225 [578]
	RCFA-A*4824A* (UGJD-09?ZCM?)	36,000 [10.5]	25,850 [7.6]	10,150 [3.0]	13.35	15.00	76	1,175 [554]
	RCFA-A*4824A* (UGJD-10?ZCM?)	36,000 [10.5]	25,850 [7.6]	10,150 [3.0]	13.35	15.00	76	1,175 [554]
	RCFA-A*4824A* (UGJD-12?RCM?)	36,000 [10.5]	25,900 [7.6]	10,100 [3.0]	13.40	15.00	76	1,225 [578]
	RCFA-A*4824A* (UGLR-07?BRQ?)	36,000 [10.5]	25,900 [7.6]	10,100 [3.0]	13.40	15.00	76	1,225 [578]
	RCFA-A*4824A* (UGLR-10?BRM?)	36,000 [10.5]	25,950 [7.6]	10,050 [2.9]	13.50	15.00	76	1,200 [566]
	RCFA-A*4824A* (UGLR-12?ARM?)	36,000 [10.5]	25,950 [7.6]	10,050 [2.9]	13.55	15.00	76	1,225 [578]
	RCFA-A*4824A* (UGPR-07?AMK?)	35,800 [10.5]	25,650 [7.5]	10,150 [3.0]	12.95	14.50	76	1,200 [566]
	RCFA-A*4824A* (UGPR-07?BRQ?)	36,000 [10.5]	25,950 [7.6]	10,050 [2.9]	13.50	15.00	76	1,200 [566]
	RCFA-A*4824A* (UGPR-10?BRM?)	36,000 [10.5]	25,800 [7.6]	10,200 [3.0]	13.30	15.00	76	1,225 [578]
	RCFA-A*4824A* (UGPR-12?ARM?)	36,200 [10.6]	25,900 [7.6]	10,300 [3.0]	13.50	15.00	76	1,250 [590]
	RCFA-H*3617A*	34,600 [10.1]	24,750 [7.3]	9,850 [2.9]	11.85	13.50	76	1,100 [519]
	RCFA-H*3617A* (UGLR-07?AMK?)	34,800 [10.2]	24,550 [7.2]	10,250 [3.0]	12.25	14.00	76	1,200 [566]
	RCFA-H*3617A* (UGPR-07?AMK?)	34,800 [10.2]	24,550 [7.2]	10,250 [3.0]	12.20	14.00	76	1,200 [566]
	RCFA-H*3621A*	34,600 [10.1]	24,750 [7.3]	9,850 [2.9]	11.85	13.50	76	1,100 [519]
	RCFA-H*3621A* (UGFD-09?ZCM?)	34,800 [10.2]	25,750 [7.5]	9,050 [2.7]	12.75	14.50	76	1,150 [543]
	RCFA-H*3621A* (UGFD-10?ZCM?)	35,000 [10.3]	25,600 [7.5]	9,400 [2.8]	12.65	14.00	76	1,175 [554]
	RCFA-H*3621A* (UGGD-09?ZCM?)	35,000 [10.3]	25,700 [7.5]	9,300 [2.7]	12.80	14.50	76	1,175 [554]
	RCFA-H*3621A* (UGGD-10?ZCM?)	35,000 [10.3]	25,750 [7.5]	9,250 [2.7]	12.85	14.50	76	1,175 [554]
	RCFA-H*3621A* (UGJD-09?ZCM?)	35,000 [10.3]	25,700 [7.5]	9,300 [2.7]	12.80	14.50	76	1,175 [554]
	RCFA-H*3621A* (UGJD-10?ZCM?)	35,000 [10.3]	25,750 [7.5]	9,250 [2.7]	12.85	14.50	76	1,175 [554]
	RCFA-H*3621A* (UGLR-07?AMK?)	34,800 [10.2]	25,550 [7.5]	9,250 [2.7]	12.50	14.00	76	1,200 [566]
	RCFA-H*3621A* (UGLR-07?BRQ?)	35,200 [10.3]	25,800 [7.6]	9,400 [2.8]	12.90	15.00	76	1,225 [578]
	RCFA-H*3621A* (UGLR-10?BRM?)	35,200 [10.3]	25,850 [7.6]	9,350 [2.7]	13.00	14.50	76	1,200 [566]
	RCFA-H*3621A* (UGPR-07?AMK?)	34,800 [10.2]	25,500 [7.5]	9,300 [2.7]	12.45	14.00	76	1,200 [566]
	RCFA-H*3621A* (UGPR-07?BRQ?)	35,200 [10.3]	25,850 [7.6]	9,350 [2.7]	13.00	14.50	76	1,200 [566]
	RCFA-H*3621A* (UGPR-10?BRM?)	35,000 [10.3]	25,700 [7.5]	9,300 [2.7]	12.75	14.50	76	1,225 [578]
	RCFA-H*4821A*	35,400 [10.4]	25,300 [7.4]	10,100 [3.0]	12.35	14.00	76	1,200 [566]
	RCFA-H*4821A* (UGFD-09?ZCM?)	35,800 [10.5]	25,850 [7.6]	9,950 [2.9]	13.25	14.35	76	1,150 [543]
	RCFA-H*4821A* (UGFD-10?ZCM?)	35,800 [10.5]	25,750 [7.5]	10,050 [2.9]	13.10	14.50	76	1,175 [554]
	RCFA-H*4821A* (UGGD-09?ZCM?)	36,000 [10.5]	25,850 [7.6]	10,150 [3.0]	13.30	15.00	76	1,175 [554]
	RCFA-H*4821A* (UGGD-10?ZCM?)	36,000 [10.5]	25,850 [7.6]	10,150 [3.0]	13.30	15.00	76	1,175 [554]
RCFA-H*4821A* (UGJD-09?ZCM?)	36,000 [10.5]	25,850 [7.6]	10,150 [3.0]	13.30	15.00	76	1,175 [554]	
RCFA-H*4821A* (UGJD-10?ZCM?)	36,000 [10.5]	25,850 [7.6]	10,150 [3.0]	13.30	15.00	76	1,175 [554]	
RCFA-H*4821A* (UGLR-07?BRQ?)	36,000 [10.5]	25,900 [7.6]	10,100 [3.0]	13.40	15.00	76	1,225 [578]	
RCFA-H*4821A* (UGLR-10?BRM?)	36,400 [10.7]	25,000 [7.3]	11,400 [3.3]	13.45	15.00	76	1,200 [566]	
RCFA-H*4821A* (UGPR-07?AMK?)	35,800 [10.5]	25,600 [7.5]	10,200 [3.0]	12.90	14.50	76	1,200 [566]	
RCFA-H*4821A* (UGPR-07?BRQ?)	36,000 [10.5]	25,950 [7.6]	10,050 [2.9]	13.50	15.00	76	1,200 [566]	
RCFA-H*4821A* (UGPR-10?BRM?)	36,000 [10.5]	25,800 [7.6]	10,200 [3.0]	13.30	15.00	76	1,225 [578]	
RCFA-H*4824A*	35,400 [10.4]	25,300 [7.4]	10,100 [3.0]	12.55	14.00	76	1,200 [566]	
RCFA-H*4824A* (UGFD-09?ZCM?)	35,800 [10.5]	25,850 [7.6]	9,950 [2.9]	13.25	14.35	76	1,150 [543]	
RCFA-H*4824A* (UGFD-10?ZCM?)	35,800 [10.5]	25,750 [7.5]	10,050 [2.9]	13.15	15.00	76	1,175 [554]	
RCFA-H*4824A* (UGFD-12?RCM?)	36,000 [10.5]	25,800 [7.6]	10,200 [3.0]	13.25	15.00	76	1,225 [578]	
RCFA-H*4824A* (UGGD-09?ZCM?)	36,000 [10.5]	25,850 [7.6]	10,150 [3.0]	13.30	15.00	76	1,175 [554]	
RCFA-H*4824A* (UGGD-10?ZCM?)	36,000 [10.5]	25,850 [7.6]	10,150 [3.0]	13.35	15.00	76	1,175 [554]	

NOTES: ① Highest sales volume tested combination required by D.O.E. test procedures.

[] Designates Metric Conversions

Performance Data @ ARI Standard Conditions—Cooling (cont.)

Model Numbers		80°F [26.5°C] DB/67°F [19.5°C] WB Indoor Air 95°F [35°C] DB Outdoor Air					Sound Rating dB	Indoor CFM [L/s]
Outdoor Unit UAPC-	Indoor Coil and/or Air Handler	Total Capacity BTU/H [kW]	Net Sensible BTU/H [kW]	Net Latent BTU/H [kW]	EER	SEER		
036JAZ	RCFA-H*4824A* (UGGD-12?RCM?)	36,000 [10.5]	25,900 [7.6]	10,100 [3.0]	13.40	15.00	76	1,225 [578]
	RCFA-H*4824A* (UGJD-09?ZCM?)	36,000 [10.5]	25,850 [7.6]	10,150 [3.0]	13.35	15.00	76	1,175 [554]
	RCFA-H*4824A* (UGJD-10?ZCM?)	36,000 [10.5]	25,850 [7.6]	10,150 [3.0]	13.35	15.00	76	1,175 [554]
	RCFA-H*4824A* (UGJD-12?RCM?)	36,000 [10.5]	25,900 [7.6]	10,100 [3.0]	13.40	15.00	76	1,225 [578]
	RCFA-H*4824A* (UGLR-07?BRQ?)	36,000 [10.5]	25,900 [7.6]	10,100 [3.0]	13.40	15.00	76	1,225 [578]
	RCFA-H*4824A* (UGLR-10?BRM?)	36,000 [10.5]	25,950 [7.6]	10,050 [2.9]	13.50	15.00	76	1,200 [566]
	RCFA-H*4824A* (UGLR-12?ARM?)	36,000 [10.5]	25,950 [7.6]	10,050 [2.9]	13.55	15.00	76	1,225 [578]
	RCFA-H*4824A* (UGPR-07?AMK?)	35,800 [10.5]	25,650 [7.5]	10,150 [3.0]	12.95	14.50	76	1,200 [566]
	RCFA-H*4824A* (UGPR-07?BRQ?)	36,000 [10.5]	25,950 [7.6]	10,050 [2.9]	13.50	15.00	76	1,200 [566]
	RCFA-H*4824A* (UGPR-10?BRM?)	36,000 [10.5]	25,800 [7.6]	10,200 [3.0]	13.30	15.00	76	1,225 [578]
	RCFA-H*4824A* (UGPR-12?ARM?)	36,200 [10.6]	25,900 [7.6]	10,300 [3.0]	13.50	15.00	76	1,250 [590]
	21AHBA36HM (RCHJ-36A1)	34,400 [10.1]	22,700 [6.7]	11,700 [3.4]	12.55	14.00	76	1,250 [590]
	UBHP-21 (RCHJ-36A1)	34,400 [10.1]	22,700 [6.7]	11,700 [3.4]	12.55	14.00	76	1,300 [613]
	UBHK-21 (RCHJ-36A2)	34,400 [10.1]	25,600 [7.5]	8,800 [2.6]	13.05	14.60	76	1,200 [566]
	RCHJ-36A2 (UGFD-07?MCK?)	33,800 [9.9]	25,000 [7.3]	8,800 [2.6]	12.05	13.00	76	1,200 [566]
	RCHJ-36A2 (UGFD-09?ZCM?)	34,000 [10.0]	25,200 [7.4]	8,800 [2.6]	12.50	13.90	76	1,200 [566]
	RCHJ-36A2 (UGFD-10?ZCM?)	34,200 [10.0]	25,400 [7.4]	8,800 [2.6]	12.70	14.15	76	1,200 [566]
	RCHJ-36A2 (UGFD-12?RCM?)	34,200 [10.0]	25,400 [7.4]	8,800 [2.6]	12.85	14.35	76	1,200 [566]
	RCHJ-36A2 (UGLR-07?AMK?)	34,400 [10.1]	25,600 [7.5]	8,800 [2.6]	13.10	13.75	76	1,200 [566]
	RCHJ-36A2 (UGLR-07?BRQ?)	34,000 [10.0]	25,200 [7.4]	8,800 [2.6]	12.35	14.00	76	1,200 [566]
	RCHJ-36A2 (UGLR-10?BRM?)	34,400 [10.1]	25,600 [7.5]	8,800 [2.6]	13.05	14.00	76	1,200 [566]
	RCHJ-36A2 (UGLR-12?ARM?)	34,400 [10.1]	25,600 [7.5]	8,800 [2.6]	13.00	14.50	76	1,200 [566]
	RCHJ-36A2 (UGPR-05?BMK?)	34,400 [10.1]	25,600 [7.5]	8,800 [2.6]	12.95	13.10	76	1,200 [566]
	RCHJ-36A2 (UGPR-07?AMK?)	34,200 [10.0]	25,400 [7.4]	8,800 [2.6]	12.60	14.00	76	1,200 [566]
	RCHJ-36A2 (UGPR-07?BRQ?)	34,200 [10.0]	25,400 [7.4]	8,800 [2.6]	12.70	14.00	76	1,200 [566]
	RCHJ-36A2 (UGPR-10?BRM?)	34,400 [10.1]	25,600 [7.5]	8,800 [2.6]	13.05	14.20	76	1,200 [566]
	RCHJ-36A2 (UGPR-12?ARM?)	34,400 [10.1]	25,600 [7.5]	8,800 [2.6]	13.15	14.50	76	1,200 [566]
	RCHJ-36A2+RXMD-C04	33,600 [9.8]	24,800 [7.3]	8,800 [2.6]	11.65	13.20	76	1,250 [590]
	RCQC-3617A (UGPR-05?BMK?)	35,000 [10.3]	26,000 [7.6]	9,000 [2.6]	12.85	14.00	76	1,200 [566]
	RCQC-3617A+RXMD-C04	34,400 [10.1]	25,400 [7.4]	9,000 [2.6]	11.85	13.40	76	1,250 [590]
	RCQC-3621A (UGFD-09?ZCM?)	34,800 [10.2]	25,800 [7.6]	9,000 [2.6]	12.55	13.90	76	1,200 [566]
	RCQC-3621A (UGFD-10?ZCM?)	34,800 [10.2]	25,800 [7.6]	9,000 [2.6]	12.75	14.15	76	1,200 [566]
	RCQC-3621A (UGPR-05?BMK?)	35,000 [10.3]	26,000 [7.6]	9,000 [2.6]	13.00	14.00	76	1,200 [566]
	RCQC-3621A (UGPR-07?AMK?)	34,800 [10.2]	25,800 [7.6]	9,000 [2.6]	12.60	14.00	76	1,200 [566]
	RCQC-3621A (UGPR-07?BRQ?)	34,800 [10.2]	25,800 [7.6]	9,000 [2.6]	12.65	14.00	76	1,200 [566]
	RCQC-3621A (UGPR-10?BRM?)	35,200 [10.3]	26,200 [7.7]	9,000 [2.6]	13.15	14.50	76	1,200 [566]
	RCQC-3621A+RXMD-C04	34,400 [10.1]	25,400 [7.4]	9,000 [2.6]	11.85	13.40	76	1,250 [590]
	UBHL-24 (RCQC-3624B)	36,800 [10.8]	26,800 [7.9]	10,000 [2.9]	13.80	15.50	76	1,225 [578]
	RCQC-4821A (UGFD-09?ZCM?)	35,800 [10.5]	26,600 [7.8]	9,200 [2.7]	12.95	14.45	76	1,200 [566]
	RCQC-4821A (UGFD-10?ZCM?)	35,800 [10.5]	26,600 [7.8]	9,200 [2.7]	13.15	14.70	76	1,200 [566]
	RCQC-4821A (UGPR-05?BMK?)	36,000 [10.5]	26,800 [7.9]	9,200 [2.7]	13.40	15.00	76	1,200 [566]
	RCQC-4821A (UGPR-07?AMK?)	35,800 [10.5]	26,600 [7.8]	9,200 [2.7]	13.00	14.50	76	1,200 [566]
	RCQC-4821A (UGPR-07?BRQ?)	35,800 [10.5]	26,600 [7.8]	9,200 [2.7]	13.05	14.50	76	1,200 [566]
	RCQC-4821A (UGPR-10?BRM?)	36,000 [10.5]	26,800 [7.9]	9,200 [2.7]	13.55	15.00	76	1,200 [566]
	RCQC-4824A (UGFD-09?ZCM?)	35,800 [10.5]	26,600 [7.8]	9,200 [2.7]	13.00	14.55	76	1,200 [566]
	RCQC-4824A (UGFD-10?ZCM?)	35,800 [10.5]	26,600 [7.8]	9,200 [2.7]	13.25	14.80	76	1,200 [566]
	RCQC-4824A (UGFD-12?RCM?)	36,000 [10.5]	26,800 [7.9]	9,200 [2.7]	13.40	15.00	76	1,200 [566]
	RCQC-4824A (UGPR-07?AMK?)	35,800 [10.5]	26,600 [7.8]	9,200 [2.7]	13.10	14.50	76	1,200 [566]
	RCQC-4824A (UGPR-07?BRQ?)	35,800 [10.5]	26,600 [7.8]	9,200 [2.7]	13.20	14.50	76	1,200 [566]
	RCQC-4824A (UGPR-10?BRM?)	36,000 [10.5]	26,800 [7.9]	9,200 [2.7]	13.60	15.00	76	1,200 [566]
RCQC-4824A (UGPR-12?ARM?)	36,200 [10.6]	27,000 [7.9]	9,200 [2.7]	13.70	15.00	76	1,200 [566]	
RCQC-4824A+RXMD-C04	35,200 [10.3]	26,000 [7.6]	9,200 [2.7]	12.25	14.05	76	1,250 [590]	
17AHLA36HM (RCSA-H*3617A*)	35,200 [10.3]	24,950 [7.3]	10,250 [3.0]	12.90	14.50	76	1,200 [566]	

NOTES: ① Highest sales volume tested combination required by D.O.E. test procedures.

[] Designates Metric Conversions

Performance Data @ ARI Standard Conditions—Cooling (cont.)

Model Numbers		80°F [26.5°C] DB/67°F [19.5°C] WB Indoor Air 95°F [35°C] DB Outdoor Air					Sound Rating dB	Indoor CFM [L/s]
Outdoor Unit UAPC-	Indoor Coil and/or Air Handler	Total Capacity BTU/H [kW]	Net Sensible BTU/H [kW]	Net Latent BTU/H [kW]	EER	SEER		
036JAZ	17AHS36AU (RCSA-H*3617A*)	34,200 [10.0]	24,150 [7.1]	10,050 [2.9]	12.00	13.50	76	1,100 [519]
	17AHS36HM (RCSA-H*3617A*)	34,200 [10.0]	24,150 [7.1]	10,050 [2.9]	12.00	13.50	76	1,100 [519]
	UHKA-HM3617 (RCSA-H*3617A*)	35,000 [10.3]	24,800 [7.3]	10,200 [3.0]	12.65	14.50	76	1,225 [578]
	UHLA-HM3617 (RCSA-H*3617A*)	35,200 [10.3]	24,950 [7.3]	10,250 [3.0]	12.90	14.50	76	1,200 [566]
	UHSA-HM3617 (RCSA-H*3617A*)	34,200 [10.0]	24,150 [7.1]	10,050 [2.9]	12.00	13.50	76	1,100 [519]
042JAZ	RCQC-4921A ①	41,000 [12.0]	30,500 [8.9]	10,500 [3.1]	12.40	14.20	76	1,400 [661]
	RCFA-A*4821A*	39,000 [11.4]	28,350 [8.3]	10,650 [3.1]	12.25	14.00	76	1,400 [661]
	RCFA-A*4821A* (UGFD-09?ZCM?)	41,500 [12.2]	30,600 [9.0]	10,900 [3.2]	12.70	14.50	76	1,325 [625]
	RCFA-A*4821A* (UGFD-10?ZCM?)	41,500 [12.2]	30,550 [9.0]	10,950 [3.2]	12.55	14.50	76	1,325 [625]
	RCFA-A*4821A* (UGGD-09?ZCM?)	42,000 [12.3]	30,850 [9.0]	11,150 [3.3]	12.65	14.50	76	1,425 [672]
	RCFA-A*4821A* (UGGD-10?ZCM?)	42,000 [12.3]	30,850 [9.0]	11,150 [3.3]	12.70	14.50	76	1,425 [672]
	RCFA-A*4821A* (UGJD-09?ZCM?)	42,000 [12.3]	30,850 [9.0]	11,150 [3.3]	12.65	14.50	76	1,425 [672]
	RCFA-A*4821A* (UGJD-10?ZCM?)	42,000 [12.3]	30,850 [9.0]	11,150 [3.3]	12.70	14.50	76	1,425 [672]
	RCFA-A*4821A* (UGLR-07?BRQ?)	39,500 [11.6]	28,850 [8.5]	10,650 [3.1]	12.95	15.00	76	1,425 [672]
	RCFA-A*4821A* (UGLR-10?BRM?)	42,500 [12.5]	31,100 [9.1]	11,400 [3.3]	13.20	15.00	76	1,375 [649]
	RCFA-A*4821A* (UGPR-07?BRQ?)	42,500 [12.5]	31,100 [9.1]	11,400 [3.3]	13.10	15.00	76	1,400 [661]
	RCFA-A*4821A* (UGPR-10?BRM?)	42,000 [12.3]	30,950 [9.1]	11,050 [3.2]	12.80	14.60	76	1,425 [672]
	RCFA-A*4824A*	39,000 [11.4]	28,350 [8.3]	10,650 [3.1]	12.25	14.00	76	1,400 [661]
	RCFA-A*4824A* (UGFD-09?ZCM?)	41,500 [12.2]	30,600 [9.0]	10,900 [3.2]	12.70	14.50	76	1,325 [625]
	RCFA-A*4824A* (UGFD-10?ZCM?)	41,500 [12.2]	30,550 [9.0]	10,950 [3.2]	12.55	14.50	76	1,325 [625]
	RCFA-A*4824A* (UGFD-12?RCM?)	42,500 [12.5]	31,100 [9.1]	11,400 [3.3]	12.70	14.50	76	1,475 [696]
	RCFA-A*4824A* (UGGD-09?ZCM?)	42,000 [12.3]	30,850 [9.0]	11,150 [3.3]	12.65	14.50	76	1,425 [672]
	RCFA-A*4824A* (UGGD-10?ZCM?)	42,000 [12.3]	30,850 [9.0]	11,150 [3.3]	12.70	14.50	76	1,425 [672]
	RCFA-A*4824A* (UGGD-12?RCM?)	42,500 [12.5]	31,150 [9.1]	11,350 [3.3]	13.00	15.00	76	1,450 [684]
	RCFA-A*4824A* (UGJD-09?ZCM?)	42,000 [12.3]	30,850 [9.0]	11,150 [3.3]	12.65	14.50	76	1,425 [672]
	RCFA-A*4824A* (UGJD-10?ZCM?)	42,000 [12.3]	30,850 [9.0]	11,150 [3.3]	12.70	14.50	76	1,425 [672]
	RCFA-A*4824A* (UGJD-12?RCM?)	42,500 [12.5]	31,150 [9.1]	11,350 [3.3]	13.00	15.00	76	1,450 [684]
	RCFA-A*4824A* (UGLR-07?BRQ?)	39,500 [11.6]	28,850 [8.5]	10,650 [3.1]	12.95	15.00	76	1,425 [672]
	RCFA-A*4824A* (UGLR-10?BRM?)	42,500 [12.5]	31,100 [9.1]	11,400 [3.3]	13.20	15.00	76	1,375 [649]
	RCFA-A*4824A* (UGLR-12?ARM?)	42,500 [12.5]	31,100 [9.1]	11,400 [3.3]	13.10	15.00	76	1,425 [672]
	RCFA-A*4824A* (UGPR-07?BRQ?)	42,500 [12.5]	31,100 [9.1]	11,400 [3.3]	13.10	15.00	76	1,400 [661]
	RCFA-A*4824A* (UGPR-10?BRM?)	42,000 [12.3]	30,950 [9.1]	11,050 [3.2]	12.80	14.60	76	1,425 [672]
	RCFA-A*4824A* (UGPR-12?ARM?)	42,500 [12.5]	31,100 [9.1]	11,400 [3.3]	13.10	15.00	76	1,400 [661]
	RCFA-H*4821A*	39,000 [11.4]	28,350 [8.3]	10,650 [3.1]	12.25	14.00	76	1,400 [661]
	RCFA-H*4821A* (UGFD-09?ZCM?)	41,500 [12.2]	30,600 [9.0]	10,900 [3.2]	12.70	14.50	76	1,325 [625]
	RCFA-H*4821A* (UGFD-10?ZCM?)	41,500 [12.2]	30,550 [9.0]	10,950 [3.2]	12.55	14.50	76	1,325 [625]
	RCFA-H*4821A* (UGGD-09?ZCM?)	42,000 [12.3]	30,850 [9.0]	11,150 [3.3]	12.65	14.50	76	1,425 [672]
	RCFA-H*4821A* (UGGD-10?ZCM?)	42,000 [12.3]	30,850 [9.0]	11,150 [3.3]	12.70	14.50	76	1,425 [672]
	RCFA-H*4821A* (UGJD-09?ZCM?)	42,000 [12.3]	30,850 [9.0]	11,150 [3.3]	12.65	14.50	76	1,425 [672]
	RCFA-H*4821A* (UGJD-10?ZCM?)	42,000 [12.3]	30,850 [9.0]	11,150 [3.3]	12.70	14.50	76	1,425 [672]
	RCFA-H*4821A* (UGLR-07?BRQ?)	39,500 [11.6]	28,850 [8.5]	10,650 [3.1]	12.95	15.00	76	1,425 [672]
	RCFA-H*4821A* (UGLR-10?BRM?)	42,500 [12.5]	31,100 [9.1]	11,400 [3.3]	13.20	14.50	76	1,375 [649]
	RCFA-H*4821A* (UGPR-07?BRQ?)	42,500 [12.5]	31,100 [9.1]	11,400 [3.3]	13.10	15.00	76	1,400 [661]
	RCFA-H*4821A* (UGPR-10?BRM?)	42,000 [12.3]	30,950 [9.1]	11,050 [3.2]	12.80	14.60	76	1,425 [672]
	RCFA-H*4824A*	39,000 [11.4]	28,350 [8.3]	10,650 [3.1]	12.25	14.00	76	1,400 [661]
	RCFA-H*4824A* (UGFD-09?ZCM?)	41,500 [12.2]	30,600 [9.0]	10,900 [3.2]	12.70	14.50	76	1,325 [625]
	RCFA-H*4824A* (UGFD-10?ZCM?)	41,500 [12.2]	30,550 [9.0]	10,950 [3.2]	12.55	14.50	76	1,325 [625]
RCFA-H*4824A* (UGFD-12?RCM?)	42,500 [12.5]	31,100 [9.1]	11,400 [3.3]	12.70	14.50	76	1,475 [696]	
RCFA-H*4824A* (UGGD-09?ZCM?)	42,000 [12.3]	30,850 [9.0]	11,150 [3.3]	12.65	14.50	76	1,425 [672]	
RCFA-H*4824A* (UGGD-10?ZCM?)	42,000 [12.3]	30,850 [9.0]	11,150 [3.3]	12.70	14.50	76	1,425 [672]	
RCFA-H*4824A* (UGGD-12?RCM?)	42,500 [12.5]	31,150 [9.1]	11,350 [3.3]	13.00	15.00	76	1,450 [684]	
RCFA-H*4824A* (UGJD-09?ZCM?)	42,000 [12.3]	30,850 [9.0]	11,150 [3.3]	12.65	14.50	76	1,425 [672]	
RCFA-H*4824A* (UGJD-10?ZCM?)	42,000 [12.3]	30,850 [9.0]	11,150 [3.3]	12.70	14.50	76	1,425 [672]	

NOTES: ① Highest sales volume tested combination required by D.O.E. test procedures.

[] Designates Metric Conversions

Performance Data @ ARI Standard Conditions—Cooling (cont.)

Model Numbers		80°F [26.5°C] DB/67°F [19.5°C] WB Indoor Air 95°F [35°C] DB Outdoor Air					Sound Rating dB	Indoor CFM [L/s]	
Outdoor Unit UAPC-	Indoor Coil and/or Air Handler	Total Capacity BTU/H [kW]	Net Sensible BTU/H [kW]	Net Latent BTU/H [kW]	EER	SEER			
042JAZ	RCFA-H*4824A* (UGJD-12?RCM?)	42,500 [12.5]	31,150 [9.1]	11,350 [3.3]	13.00	15.00	76	1,450 [684]	
	RCFA-H*4824A* (UGLR-07?BRQ?)	39,500 [11.6]	28,850 [8.5]	10,650 [3.1]	12.95	15.00	76	1,425 [672]	
	RCFA-H*4824A* (UGLR-10?BRM?)	42,500 [12.5]	31,100 [9.1]	11,400 [3.3]	13.20	15.00	76	1,375 [649]	
	RCFA-H*4824A* (UGLR-12?ARM?)	42,500 [12.5]	31,100 [9.1]	11,400 [3.3]	13.10	15.00	76	1,425 [672]	
	RCFA-H*4824A* (UGPR-07?BRQ?)	42,500 [12.5]	31,100 [9.1]	11,400 [3.3]	13.10	15.00	76	1,400 [661]	
	RCFA-H*4824A* (UGPR-10?BRM?)	42,000 [12.3]	30,950 [9.1]	11,050 [3.2]	12.80	14.60	76	1,425 [672]	
	RCFA-H*4824A* (UGPR-12?ARM?)	42,500 [12.5]	31,100 [9.1]	11,400 [3.3]	13.10	15.00	76	1,400 [661]	
	RCHJ-48A1		39,000 [11.4]	29,000 [8.5]	10,000 [2.9]	11.65	13.25	76	1,400 [661]
	24AHBA48HM (RCHJ-48A1)		40,000 [11.7]	26,650 [7.8]	13,350 [3.9]	12.75	14.00	76	1,500 [708]
	UBHK-24 (RCHJ-48A1)		40,000 [11.7]	30,000 [8.8]	10,000 [2.9]	11.70	14.80	76	1,400 [661]
	UBHP-24 (RCHJ-48A1)		40,000 [11.7]	26,650 [7.8]	13,350 [3.9]	12.75	14.00	76	1,500 [708]
	RCHJ-48A1 (UGFD-09?ZCM?)		39,500 [11.6]	29,500 [8.6]	10,000 [2.9]	12.00	13.50	76	1,400 [661]
	RCHJ-48A1 (UGFD-10?ZCM?)		39,500 [11.6]	29,500 [8.6]	10,000 [2.9]	12.25	13.55	76	1,400 [661]
	RCHJ-48A1 (UGFD-12?RCM?)		39,500 [11.6]	29,500 [8.6]	10,000 [2.9]	12.40	14.00	76	1,400 [661]
	RCHJ-48A1 (UGLR-07?BRQ?)		39,500 [11.6]	29,500 [8.6]	10,000 [2.9]	12.05	14.00	76	1,400 [661]
	RCHJ-48A1 (UGLR-10?BRM?)		40,000 [11.7]	30,000 [8.8]	10,000 [2.9]	12.70	14.00	76	1,400 [661]
	RCHJ-48A1 (UGLR-12?ARM?)		40,000 [11.7]	30,000 [8.8]	10,000 [2.9]	12.70	14.00	76	1,400 [661]
	RCHJ-48A1 (UGPR-07?BRQ?)		39,500 [11.6]	29,500 [8.6]	10,000 [2.9]	12.30	14.00	76	1,400 [661]
	RCHJ-48A1 (UGPR-10?BRM?)		40,000 [11.7]	30,000 [8.8]	10,000 [2.9]	12.75	14.00	76	1,400 [661]
	RCHJ-48A1 (UGPR-12?ARM?)		40,000 [11.7]	30,000 [8.8]	10,000 [2.9]	12.80	14.20	76	1,400 [661]
	RBHL-24 (RCQC-3624B)		41,500 [12.2]	29,250 [8.6]	12,250 [3.6]	13.35	15.45	76	1,300 [613]
	RCQC-4821A		40,500 [11.9]	30,100 [8.8]	10,400 [3.0]	11.95	13.55	76	1,400 [661]
	RCQC-4821A (UGFD-10?ZCM?)		40,500 [11.9]	30,100 [8.8]	10,400 [3.0]	12.30	13.80	76	1,400 [661]
	RCQC-4821A (UGPR-07?BRQ?)		40,500 [11.9]	30,100 [8.8]	10,400 [3.0]	12.30	13.50	76	1,400 [661]
	RCQC-4821A (UGPR-10?BRM?)		41,000 [12.0]	30,600 [9.0]	10,400 [3.0]	12.85	14.50	76	1,400 [661]
	RCQC-4824A		40,500 [11.9]	30,100 [8.8]	10,400 [3.0]	11.95	13.55	76	1,400 [661]
	RCQC-4824A (UGFD-09?ZCM?)		40,500 [11.9]	30,100 [8.8]	10,400 [3.0]	12.15	13.60	76	1,400 [661]
	RCQC-4824A (UGFD-10?ZCM?)		40,500 [11.9]	30,100 [8.8]	10,400 [3.0]	12.40	13.95	76	1,400 [661]
	RCQC-4824A (UGFD-12?RCM?)		40,500 [11.9]	30,100 [8.8]	10,400 [3.0]	12.55	14.15	76	1,400 [661]
	RCQC-4824A (UGPR-07?BRQ?)		40,500 [11.9]	30,100 [8.8]	10,400 [3.0]	12.40	13.50	76	1,400 [661]
	RCQC-4824A (UGPR-10?BRM?)		41,000 [12.0]	30,600 [9.0]	10,400 [3.0]	12.90	14.50	76	1,400 [661]
	RCQC-4824A (UGPR-12?ARM?)		41,000 [12.0]	30,600 [9.0]	10,400 [3.0]	12.95	14.50	76	1,400 [661]
	RCQC-4921A (UGPR-10?BRM?)		41,500 [12.2]	31,000 [9.1]	10,500 [3.1]	13.30	15.00	76	1,400 [661]
	RCQC-4924A		41,000 [12.0]	30,500 [8.9]	10,500 [3.1]	12.40	14.20	76	1,400 [661]
	RCQC-4924A (UGFD-10?ZCM?)		41,500 [12.2]	31,000 [9.1]	10,500 [3.1]	12.85	14.25	76	1,400 [661]
	RCQC-4924A (UGFD-12?RCM?)		41,500 [12.2]	31,000 [9.1]	10,500 [3.1]	13.00	14.45	76	1,400 [661]
	RCQC-4924A (UGPR-07?BRQ?)		41,500 [12.2]	31,000 [9.1]	10,500 [3.1]	12.85	14.00	76	1,400 [661]
	RCQC-4924A (UGPR-10?BRM?)		42,000 [12.3]	31,400 [9.2]	10,600 [3.1]	13.40	14.50	76	1,400 [661]
	RCQC-4924A (UGPR-12?ARM?)		42,000 [12.3]	31,400 [9.2]	10,600 [3.1]	13.40	14.50	76	1,400 [661]
	21AHS42AU (RCSA-A*4821A*)		41,500 [12.2]	30,550 [9.0]	10,950 [3.2]	12.45	14.00	76	1,350 [637]
21AHLA48HM (RCSA-H*4821A*)		42,500 [12.5]	31,250 [9.2]	11,250 [3.3]	13.45	15.00	76	1,400 [661]	
21AHS42HM (RCSA-H*4821A*)		41,500 [12.2]	30,550 [9.0]	10,950 [3.2]	12.45	14.00	76	1,350 [637]	
UHKA-HM4821 (RCSA-H*4821A*)		42,500 [12.5]	31,200 [9.1]	11,300 [3.3]	13.35	15.00	76	1,400 [661]	
UHLA-HM4821 (RCSA-H*4821A*)		42,500 [12.5]	31,250 [9.2]	11,250 [3.3]	13.45	15.00	76	1,400 [661]	
UHSA-HM4221 (RCSA-H*4821A*)		41,500 [12.2]	30,550 [9.0]	10,950 [3.2]	12.45	14.00	76	1,350 [637]	
048JAZ	RCQC-4924A ①	47,000 [13.8]	35,210 [10.3]	11,790 [3.5]	12.55	14.05	76	1,600 [755]	
	RCFA-A*4821A*	45,000 [13.2]	32,200 [9.4]	12,800 [3.8]	12.10	14.00	76	1,500 [708]	
	RCFA-A*4824A*	45,000 [13.2]	32,200 [9.4]	12,800 [3.8]	12.10	14.00	76	1,500 [708]	
	RCFA-H*4821A*	45,000 [13.2]	32,200 [9.4]	12,800 [3.8]	12.10	14.00	76	1,500 [708]	
	RCFA-H*4824A*	45,000 [13.2]	32,200 [9.4]	12,800 [3.8]	12.10	14.00	76	1,500 [708]	
	24AHBA48HM (RCHJ-48A1)	45,000 [13.2]	30,450 [8.9]	14,550 [4.3]	12.70	14.00	76	1,700 [802]	
	UBHP-24 (RCHJ-48A1)	45,000 [13.2]	30,450 [8.9]	14,550 [4.3]	12.70	14.00	76	1,700 [802]	
RCHJ-48A2	43,000 [12.6]	29,150 [8.5]	13,850 [4.1]	11.50	13.00	76	1,600 [755]		

NOTES: ① Highest sales volume tested combination required by D.O.E. test procedures.

[] Designates Metric Conversions

Performance Data @ ARI Standard Conditions—Cooling (cont.)

Model Numbers		80°F [26.5°C] DB/67°F [19.5°C] WB Indoor Air 95°F [35°C] DB Outdoor Air					Sound Rating dB	Indoor CFM [L/s]
Outdoor Unit UAPC-	Indoor Coil and/or Air Handler	Total Capacity BTU/H [kW]	Net Sensible BTU/H [kW]	Net Latent BTU/H [kW]	EER	SEER		
048JAZ	UBHK-24 (RCHJ-48A2)	44,500 [13.0]	33,900 [9.9]	10,600 [3.1]	12.80	14.05	76	1,600 [755]
	RCHJ-48A2 (UGLR-10?BRM?)	43,500 [12.7]	29,600 [8.7]	13,900 [4.1]	12.15	13.50	76	1,575 [743]
	RCHJ-48A2 (UGLR-12?ARM?)	43,500 [12.7]	29,700 [8.7]	13,800 [4.0]	12.25	13.50	76	1,600 [755]
	RCHJ-48A2 (UGPR-07?BRQ?)	43,500 [12.7]	29,550 [8.7]	13,950 [4.1]	12.10	13.50	76	1,625 [767]
	RCHJ-48A2 (UGPR-12?ARM?)	43,500 [12.7]	29,600 [8.7]	13,900 [4.1]	12.20	13.50	76	1,575 [743]
	RCQC-4824A	46,000 [13.5]	34,800 [10.2]	11,200 [3.3]	12.30	13.55	76	1,600 [755]
	UBHL-25 (RCQC-4824A)	47,500 [13.9]	36,450 [10.7]	11,050 [3.2]	13.30	15.45	76	1,550 [731]
	RCQC-4824A (UGFD-12?RCM?)	46,000 [13.5]	34,800 [10.2]	11,200 [3.3]	12.50	13.60	76	1,600 [755]
	RCQC-4824A (UGPR-10?BRM?)	46,500 [13.6]	35,300 [10.3]	11,200 [3.3]	12.80	14.00	76	1,600 [755]
	RCQC-4824A (UGPR-12?ARM?)	46,000 [13.5]	34,800 [10.2]	11,200 [3.3]	12.80	13.50	76	1,600 [755]
	RCQC-4921A	46,500 [13.6]	35,200 [10.3]	11,300 [3.3]	12.65	14.15	76	1,400 [661]
	RCQC-4921A (UGFD-10?ZCM?)	46,500 [13.6]	35,200 [10.3]	11,300 [3.3]	12.90	14.25	76	1,400 [661]
	RCQC-4921A (UGPR-07?BRQ?)	46,500 [13.6]	35,200 [10.3]	11,300 [3.3]	12.85	14.00	76	1,400 [661]
	RCQC-4921A (UGPR-10?BRM?)	47,000 [13.8]	35,700 [10.5]	11,300 [3.3]	13.45	15.00	76	1,400 [661]
	RCQC-4924A (UGFD-09?ZCM?)	48,000 [14.1]	35,800 [10.5]	12,200 [3.6]	12.55	14.95	76	1,600 [755]
	RCQC-4924A (UGFD-10?ZCM?)	47,500 [13.9]	35,550 [10.4]	11,950 [3.5]	12.20	14.50	76	1,625 [767]
	RCQC-4924A (RGFD-12?RCM?)	48,500 [14.2]	36,100 [10.6]	12,400 [3.6]	12.85	15.30	76	1,650 [779]
	RCQC-4924A (UGPR-07?BRQ?)	48,000 [14.1]	36,050 [10.6]	11,950 [3.5]	13.05	15.50	76	1,625 [767]
	RCQC-4924A (UGPR-10?BRM?)	48,000 [14.1]	35,000 [10.3]	13,000 [3.8]	12.75	15.00	76	1,625 [767]
	RCQC-4924A (UGPR-12?ARM?)	48,500 [14.2]	36,100 [10.6]	12,400 [3.6]	13.10	15.50	76	1,575 [743]
	21AHS484AU (RCSA-A*4821A*)	48,000 [14.1]	35,850 [10.5]	12,150 [3.6]	12.80	14.00	76	1,525 [720]
	21AHLA48HM (RCSA-H*4821A*)	45,500 [13.3]	32,600 [9.6]	12,900 [3.8]	12.65	14.50	76	1,575 [743]
	21AHS484AU (RCSA-H*4821A*)	45,000 [13.2]	32,200 [9.4]	12,800 [3.8]	12.20	14.00	76	1,500 [708]
	21AHS484HM (RCSA-H*4821A*)	45,000 [13.2]	32,200 [9.4]	12,800 [3.8]	12.20	14.00	76	1,500 [708]
	UHKA-HM4821 (RCSA-H*4821A*)	45,500 [13.3]	32,550 [9.5]	12,950 [3.8]	12.60	14.50	76	1,575 [743]
	UHLA-HM4821 (RCSA-H*4821A*)	45,500 [13.3]	32,600 [9.6]	12,900 [3.8]	12.65	14.50	76	1,575 [743]
	UHSA-HM4821 (RCSA-H*4821A*)	45,000 [13.2]	32,200 [9.4]	12,800 [3.8]	12.20	14.00	76	1,500 [708]
	24AHLA48HM (RCSA-H*4824A*)	45,500 [13.3]	33,000 [9.7]	12,500 [3.7]	13.10	15.00	76	1,600 [755]
UHKA-HM4824 (RCSA-H*4824A*)	46,000 [13.5]	33,000 [9.7]	13,000 [3.8]	13.05	15.00	76	1,625 [767]	
UHLA-HM4824 (RCSA-H*4824A*)	45,500 [13.3]	33,000 [9.7]	12,500 [3.7]	13.10	15.00	76	1,600 [755]	
UHSA-HM4824 (RCSA-H*4824A*)	45,000 [13.2]	32,200 [9.4]	12,800 [3.8]	12.20	14.00	76	1,500 [708]	
060JAZ	RCQC-6124A ①	54,500 [16.0]	40,400 [11.8]	14,100 [4.1]	12.30	14.10	78	1,700 [802]
	RCFA-A*6024A*	56,000 [16.4]	41,650 [12.2]	14,350 [4.2]	12.25	14.00	78	1,700 [802]
	RCFA-H*6024A*	56,000 [16.4]	41,650 [12.2]	14,350 [4.2]	12.25	14.00	78	1,700 [802]
	RCHJ-60A1	50,500 [14.8]	37,500 [11.0]	13,000 [3.8]	11.35	13.00	78	1,800 [849]
	25AHBA60HM (RCHJ-60A1)	51,500 [15.1]	34,950 [10.2]	16,550 [4.8]	12.00	13.50	78	1,800 [849]
	UBHK-25 (RCHJ-60A1)	51,500 [15.1]	38,500 [11.3]	13,000 [3.8]	12.55	14.15	78	1,800 [849]
	UBHP-25 (RCHJ-60A1)	51,500 [15.1]	34,950 [10.2]	16,550 [4.8]	12.00	13.50	78	1,800 [849]
	RCHJ-61A1	55,000 [16.1]	40,800 [12.0]	14,200 [4.2]	12.15	13.90	78	1,800 [849]
	UBHK-25 (RCHJ-61A1)	56,000 [16.4]	41,800 [12.2]	14,200 [4.2]	13.20	15.00	78	1,800 [849]
	UBHL-26 (RCQC-6024A)	56,000 [16.4]	40,950 [12.0]	15,050 [4.4]	13.05	15.00	78	1,650 [779]
	24AHLA60HM (RCSA-H*6024A*)	56,500 [16.6]	41,450 [12.1]	15,050 [4.4]	13.00	14.50	78	1,800 [849]
	UHKA-HM6024 (RCSA-H*6024A*)	56,500 [16.6]	41,450 [12.1]	15,050 [4.4]	12.95	14.50	78	1,800 [849]
	UHLA-HM6024 (RCSA-H*6024A*)	56,500 [16.6]	41,450 [12.1]	15,050 [4.4]	13.00	14.50	78	1,800 [849]

NOTES: ① Highest sales volume tested combination required by D.O.E. test procedures.

[] Designates Metric Conversions

Electrical and Physical Data

Model Number UAPC-	ELECTRICAL					PHYSICAL							
	Phase Frequency (Hz) Voltage (Volts)	Compressor		Fan Motor Full Load Amperes (FLA)	Minimum Circuit Ampacity Amperes	Fuse or HACR Circuit Breaker		Outdoor Coil			R22 Oz. [g]	Weight	
		Rated Load Amperes (RLA)	Locked Rotor Amperes (LRA)			Minimum Amperes	Maximum Amperes	Face Area Sq. Ft. [m ²]	No. Rows	CFM [L/s]		Net Lbs. [kg]	Shipping Lbs. [kg]
024JAZ	1-60-208/230	10.9/10.9	54	.75	15/15	20/20	25/25	15.8 [1.47]	1.00	2285 [1078]	114 [3232]	190 [86.2]	200 [90.7]
030JAZ	1-60-208/230	14.1/14.1	68	.75	19/19	20/20	30/30	15.8 [1.47]	1.00	2285 [1078]	120 [3402]	200 [90.7]	210 [95.3]
036JAZ	1-60-208/230	13.5/13.5	73	1.5	19/19	25/25	30/30	23.0 [2.14]	1.00	3900 [1840]	160 [4536]	230 [104.3]	240 [108.9]
042JAZ	1-60-208/230	16.5/16.5	95	1.0	22/22	30/30	35/35	15.4 [1.43]	2.00	3190 [1505]	168 [4763]	235 [106.6]	245 [111.1]
048JAZ	1-60-208/230	17.9/17.9	104	1.5	24/24	30/30	40/40	22.4 [2.08]	2.00	3500 [1652]	288 [8164]	300 [136.1]	310 [140.6]
060JAZ	1-60-208/230	19.9/19.9	137	1.5	27/27	35/35	45/45	22.4 [2.08]	2.00	3500 [1652]	296 [8391]	305 [138.3]	315 [142.9]

Unit Dimensions

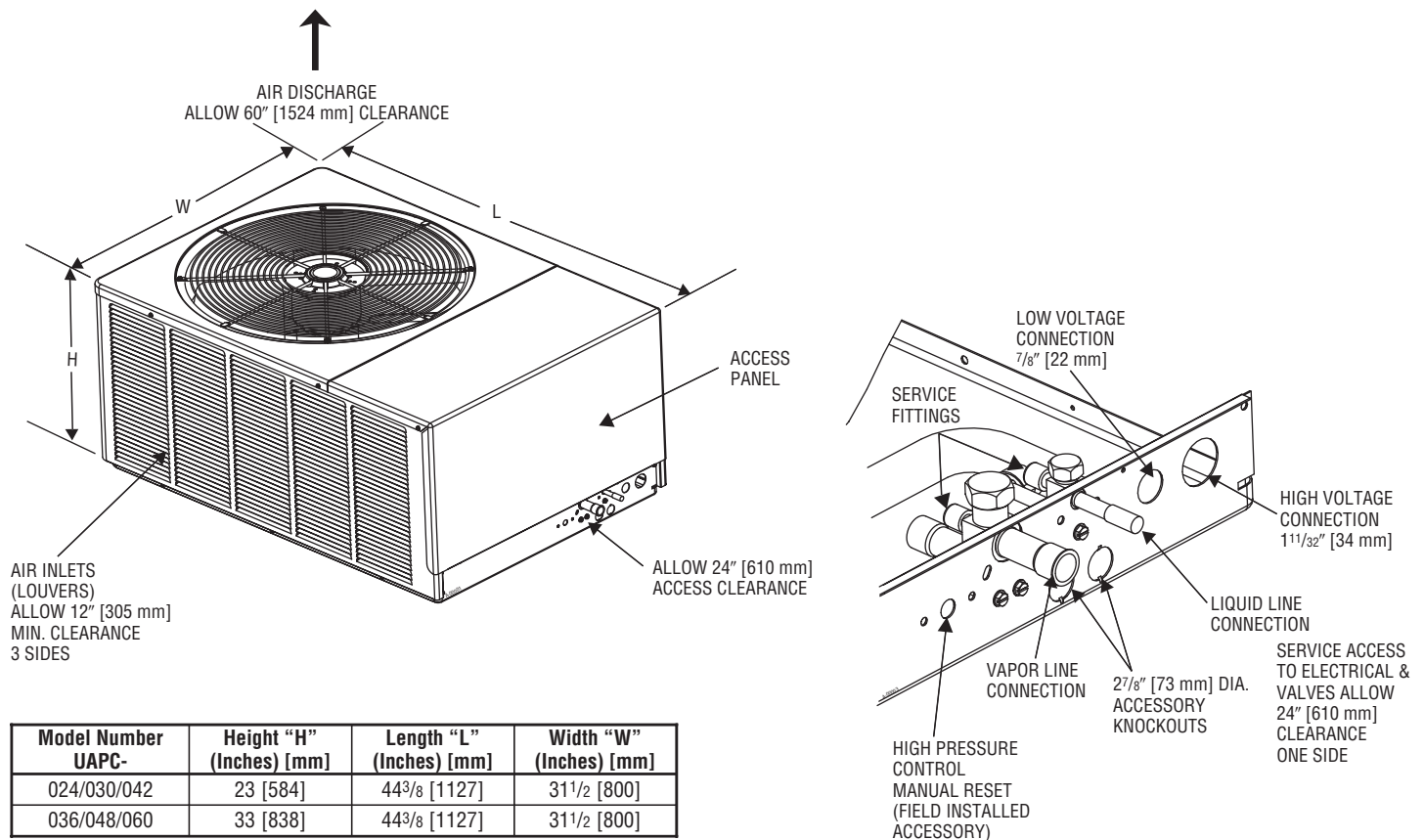

Model Number UAPC-	Height "H" (Inches) [mm]	Length "L" (Inches) [mm]	Width "W" (Inches) [mm]
024/030/042	23 [584]	44 ³ / ₈ [1127]	31 ¹ / ₂ [800]
036/048/060	33 [838]	44 ³ / ₈ [1127]	31 ¹ / ₂ [800]

[] Designates Metric Conversions

GENERAL TERMS OF LIMITED WARRANTY

Ruud will furnish a replacement for any part of this product which fails in normal use and service within the applicable period stated, in accordance with the terms of the limited warranty.

For Complete Details of the Limited Warranty, Including Applicable Terms and Conditions, See Your Local Installer or Contact the Manufacturer for a Copy.

Condenser Coil leaks caused by factory defectsFive (5) Years
CompressorTen (10) Years
*Any Other PartFive (5) Years

*This five year limited warranty is applicable only to single-phase products installed in residential applications on or after January 1, 2001

BEFORE PURCHASING THIS APPLIANCE, READ IMPORTANT ENERGY COST AND EFFICIENCY INFORMATION AVAILABLE FROM YOUR RETAILER.

Condensing Unit Refrigerant Line Size Information

System Capacity	Liquid Line Connection Size (Inch I.D.)	Line Size (Inch O.D.) [mm]	Liquid Line Size – Outdoor Unit Above Indoor Coil (Cooling Only – Does not apply to Heat Pumps)						Liquid Line Size Cooling Only With Outdoor Unit Below Indoor Coil					
			Total Equivalent Length—Feet [m]						Total Equivalent Length—Feet [m]					
			25 [7.62]	50 [15.24]	75 [22.86]	100 [30.48]	125 [38.10]	150 [45.72]	25 [7.62]	50 [15.24]	75 [22.86]	100 [30.48]	125 [38.10]	150 [45.72]
			Minimum Vertical Separation—Feet [m]						Maximum Vertical Separation—Feet [m]					
2 Ton	5/16"	1/4* [6.35]	0	5 [1.52]	27 [8.23]	48 [14.63]	69 [21.03]	91 [27.74]	16 [4.88]	N/A	N/A	N/A	N/A	N/A
		5/16 [7.94]	0	0	0	0	0	0	25 [7.62]	26 [7.92]	21 [6.40]	15 [4.57]	10 [3.05]	5 [1.52]
		3/8 [9.53]	0	0	0	0	0	0	25 [7.62]	38 [11.58]	36 [10.97]	35 [10.67]	33 [10.06]	31 [9.45]
2 1/2 Ton	5/16"	1/4* [6.35]	0	34 [10.36]	69 [21.03]	N/A	N/A	N/A	0	N/A	N/A	N/A	N/A	N/A
		5/16 [7.94]	0	0	0	0	9 [2.74]	18 [5.49]	25 [7.62]	17 [5.18]	8 [2.44]	0	N/A	N/A
		3/8 [9.53]	0	0	0	0	0	0	25 [7.62]	37 [11.28]	34 [10.36]	31 [9.45]	29 [8.84]	26 [7.92]
3 Ton	5/16"	5/16* [7.94]	0	0	0	6 [1.83]	17 [5.18]	28 [8.53]	25 [7.62]	15 [4.57]	4 [1.22]	N/A	N/A	N/A
		3/8 [9.53]	0	0	0	0	0	0	25 [7.62]	30 [9.14]	26 [7.92]	23 [7.01]	19 [5.79]	16 [4.88]
3 1/2 Ton	5/16"	5/16* [7.94]	0	0	0	13 [3.96]	28 [8.53]	43 [13.11]	25 [7.62]	17 [5.18]	2 [0.61]	N/A	N/A	N/A
		3/8 [9.53]	0	0	0	0	0	0	25 [7.62]	37 [11.28]	32 [9.75]	28 [8.53]	23 [7.01]	18 [5.49]
4 Ton	3/8"	3/8* [9.53]	0	0	0	0	0	0	25 [7.62]	33 [10.06]	27 [8.23]	21 [6.40]	15 [4.57]	9 [2.74]
		1/2 [12.57]	0	0	0	0	0	0	25 [7.62]	43 [13.11]	42 [12.80]	40 [12.19]	39 [11.89]	38 [11.58]
5 Ton	3/8"	3/8* [9.53]	0	0	0	0	0	9 [2.74]	25 [7.62]	25 [7.62]	17 [5.18]	8 [2.44]	0	N/A
		1/2 [12.57]	C	0	0	0	0	0	25 [7.62]	39 [11.89]	37 [11.28]	36 [10.97]	34 [10.36]	32 [9.75]

NOTES: *Standard line size
N/A = Application not recommended.

Suction Line Length/Size versus Capacity Multiplier (R-22)							
Unit Size		2 Ton	2 1/2 Ton	3 Ton	3 1/2 Ton	4 Ton	5 Ton
Suction Line Connection Size		3/4" I.D.	3/4" I.D.	7/8" I.D.	7/8" I.D.	7/8" I.D.	7/8" I.D.
Suction Line Run—Feet [m]		5/8" [15.88 mm] O.D. Optional 3/4" [19.05 mm] O.D. Standard* 7/8" [22.23 mm] O.D. Optional		3/4" [19.05 mm] O.D. Optional 7/8" [22.23 mm] O.D. Standard* 1 1/8" [28.58 mm] O.D. Standard*		7/8" [22.23 mm] O.D. Optional 1 1/8" [28.58 mm] O.D. Standard* 1 3/8" [34.93 mm] O.D. Optional	
25' [7.62]	Optional	.99	.98	.99	.99	.99	.99
	Standard	1.00	1.00	1.00	1.00	1.00	1.00
	Optional	1.00	1.00	N/A	1.00	N/A	N/A
50' [15.24]	Optional	.96	.96	.98	.97	.98	.97
	Standard	.99	.98	.99	.98	.99	.99
	Optional	.99	.99	N/A	1.00	N/A	N/A
100' [30.48]	Optional	.92	.94	.95	.93	.95	.95
	Standard	.96	.96	.96	.96	.98	.98
	Optional	.97	.97	N/A	.98	N/A	N/A
150' [45.72]	Optional	.89	.92	.93	.92	.93	.93
	Standard	.93	.93	.94	.94	.96	.96
	Optional	.95	.95	N/A	.96	N/A	N/A

NOTES: *Standard line size
N/A = Line size not recommended due to inadequate oil return.

[] Designates Metric Conversions

<p>Before proceeding with installation, refer to installation instructions packaged with each model, as well as complying with all Federal, State, Provincial, and Local codes, regulations, and practices.</p>	<p>RUUD AIR CONDITIONING DIVISION</p> <p>5600 Old Greenwood Road, Fort Smith, Arkansas 72908</p>	
--	---	---

"In keeping with its policy of continuous progress and product improvement, Ruud reserves the right to make changes without notice."