

CONDENSING UNITS

Equipped with the Award Winning *Comfort Control System™*



- Increased Reliability
- On-Board Diagnostics
- Fault Recall
- *Active Protection™*

R-410A
earth friendly refrigerant

UASL- JEZ

Two-Stage

Efficiencies up to 18.50 SEER

Nominal Size 2 to 3 Tons [7.03 kW] to [10.6 kW]

Two Models

Cooling Capacity

24,000 to 37,600 BTU/HR

[7.03 kW] to [11.02 kW]



RUUD ULTRA[®] Series

The Ruud *Ultra Series™* High Efficiency Two-Stage UASL- JEZ Condensing Unit was designed with performance in mind. These units offer comfort, energy conservation and dependability for single, multi-family and light commercial applications.

The Ruud *Ultra Series™* Two-Stage UASL- JEZ Condensing Units are the result of an ongoing development program for improved efficiencies. With system SEER's ranging to 18.50, these units continue a tradition of high efficiency.

- The *Comfort Control System™* provides on-board diagnostics and fault history for condensing units with single-phase compressors by detecting system and electrical problems without adding sensors. It can also communicate "fault codes" to enabled "L terminal" thermostats. The integrated diagnostics with *Active Protection™* prevents compressor operation when potentially harmful conditions are detected.
- 7-Segment LED Display is exclusive only to Ruud products. The information-display quickly and accurately shows technicians the source of malfunctions.
- Features a ten-year conditional unit replacement warranty when properly installed with a new Ruud *Ultra Series™* Air Handler or Ruud Indoor Coil with a Ruud *Ultra Series™* Gas Furnace. See product warranty card for additional information.
- Reliable Two-Stage Scroll™ Compressor for precise temperature control providing ultimate comfort.
- Comfort Alert™ Diagnostics comes installed in each Ruud *Ultra Series* model.
- All controls are accessible by removing one service panel. Removable top grille provides access to the condenser fan motor and condenser coil.
- Attractive, louvered wrap-around jacket protects the coil from yard hazards and weather extremes. Top grille is steel reinforced for extra strength. Cabinet is powder painted for all-weather protection.
- Air is discharged upward away from bushes and shrubs. The discharge pattern of the top grille provides minimum air restriction, resulting in quiet fan operation.
- Exclusive Combination Grille/Motor Mount secures the motor to the underside of the discharge grille. The grille protects the motor windings and bearings from rain and snow.
- For quiet operation and improved efficiency, the 3 ton model feature the GE® ECM two-speed motor with a 3-blade outdoor fan.
- All models meet or exceed a 1000-hour salt spray test per ASTM B117 Standard Practice for Operating Salt Spray Testing Apparatus.
- On-demand dehumidification terminal, when matched with a *Ultra Series* Air Handler or premium ECM Gas Furnace products, adjusts airflow to help control humidity for unsurpassed comfort in the cooling mode.

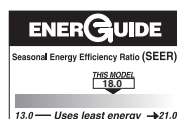

FEATURES & BENEFITS OF THE *COMFORT CONTROL SYSTEM*[™]

- The Ruud exclusive 7-Segment LED Display easily shows system operating status codes and diagnostic codes.

- A Sealed Switch replaces the standard



contactor and features optical control and latching mechanism. The sealed switch prevents infiltration of insects and dust. A minimal switching arc, by the optical control, offers greater reliability. The latching mechanism consumes less power while reducing chatter.



- The Status Indication and System Diagnostics feature thermostat communication capability, built-in diagnostics, high & low voltage monitoring and high & low pressure switch monitoring. The thermostat communication capability alerts the homeowner to any necessary service requirements. Faster, more accurate service is provided by the built-in diagnostics, by providing the HVAC professional with dependable information. With the high and low voltage monitoring feature, the control provides alerts for out-of-range conditions. In addition, high and low pressure-switch monitoring prevents the system from operating outside of its normal parameters.



- The fault recall feature will allow for the last six fault-codes to be displayed, and will retain these codes even if power failure occurs.
- Built-in short-cycle protection allows the compressor to restart easily without oil removal.
- A 30-second minimum run-time for every compressor call allows the oil to return to the compressor.
- *Active Protection* monitors the system to prevent nuisance lockouts and prevents compressor operation when potentially harmful conditions are detected.
- The compressor and fan are controlled independently, which reduces the starting load and light dimming.
- A manual push-button is offered to operate the compressor and fan for 5 seconds to allow for an operation check.
- In order to save time and money, replacement automotive fuses can be utilized instead of replacing the entire control board.

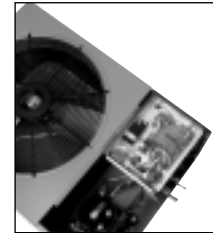

STANDARD FEATURES

UASL- JEZ Condensing Units

1. Scroll compressor is hermetically sealed and incorporates internal high temperature motor overload protection, and durable insulation on the motor windings. It is externally mounted on rubber grommets to reduce vibration and noise.
2. Compressors have an internal pressure relief assembly to protect against excessive pressure differential.
3. All refrigerant connections are on the exterior of the unit, located close to the ground for neat appearing installations.
4. Cabinet is constructed of powder painted galvanized steel. The full wrap-around louvered grille protects the coil from damage.
5. Sound Blanket-enhanced compressor sound blanket is standard.
6. Copper tube—aluminum fin coils are used on all models.
7. The control box is located in the top corner of the cabinet providing for easy access through a service panel.
8. Service valves are standard on all models.
9. Field connections for power and control wiring are kept separate.
10. Every unit is factory charged and run-tested.
11. Separate compressor compartment for easy service access.
12. Drawn, painted base pan for extra corrosion resistance and sound reduction.
13. The **UASL- JEZ** has a 10-year limited parts warranty, plus a 10-year conditional unit replacement warranty. Refer to the General Terms of Limited Warranty for more details.
14. **Hard Start Kits**—Standard on all JEZ models.
15. Control Box Cover.
16. The UASL- JEZ is shipped with a liquid line filter drier, and also features factory-installed low and high pressure controls.

Problem-Solving Accuracy

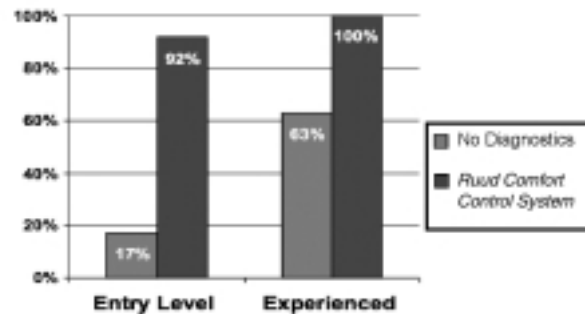

2-STAGE SCROLL ULTRA TECH[™] COMPRESSOR

The 2-Stage Scroll UltraTech[™] compressor is the key to efficiency for this Ruud model. It's the latest in high-efficiency compressor technology. The advanced scroll compressor offers low noise and vibration characteristics and features tolerance to liquid refrigerant and system contamination. The Scroll UltraTech[™] also has low start torque, eliminating start problems in the field. And its unique design enables the UASL- JEZ condensing unit to perform efficiently, quietly and reliably.



All controls and compressor are accessible for servicing by removal of the service panel.

Accessories

- **Low Ambient Control**—Cycles outdoor fan to maintain adequate condensing pressures assuring liquid refrigerant flow to the coil. Allows indoor cooling with outdoor temperatures down to 0°F [-17.8°C]. (Model No. RXAD-A08). It is recommended that this control be installed in units to be operated at outdoor ambient temperatures under 70°F [21°C].
- **Thermostats**



300-Series *
Deluxe Programmable



200-Series *
Programmable



100-Series *
Non-Programmable

400-Series *
Special Applications/Programmable

Brand	Unique Model Number Prefix	Descriptor (3 Characters)	Series (3 Characters)	System (2 Characters)	Type (2 Characters)
UHC	-	TST	101	GE	MS
UHC=Ruud		TST=Thermostat	100=Non-Programmable 200=Programmable 300=Deluxe Programmable 400=Special Applications/ Programmable	GE=Gas/Oil/Electric HP=Heat Pump MD=Modulating Furnace DF=Dual Fuel UN=Universal AC/HP/GE	SS=Single-Stage MS=Multi-Stage

* Photos are representative. Actual models may vary.

For detailed thermostat match-up information, see specification sheet form number T22-001.

- **Compressor Crankcase Heater** (Model No. 44-17402-44CCH) Add to minimize refrigeration migration and to help eliminate any startup noise or bearing “wash out”.

[] Designates Metric Conversions

Model Number Identification

U	A	S	L	—	036	J	E	Z
RUUD	REMOTE CONDENSING UNIT	18-SEER	DESIGN SERIES		COOLING CAPACITY	ELECTRICAL DESIGNATION	VARIATIONS	COOLING CONNECTION FITTING
			L = FIRST DESIGN SERIES	024 = 24,000 BTU/HR [7.03 kW] 036 = 36,000 BTU/HR [10.55 kW]		J = 208/230V-1-60	E = EQUIPPED WITH THE COMFORT CONTROL SYSTEM™	Z = SWEAT W/SCROLL

Performance Data @ ARI Standard Conditions—Cooling

Outdoor Unit UASL-	Model Numbers		Stage	ARI Cooling Performance 80°F [26.5°C] DB / 67°F [19.5°C] WB Indoor Air 95°F [35°C] DB Outdoor Air							
				Net Sensible BTU/H [kW]	Net Latent BTU/H [kW]	ARI Ratings			Indoor Airflow CFM [L/s]	Sound Rating db	
	Total Capacity BTU/H [kW]	SEER				EER					
024JEZ	RCSN-H*2421A*	UHPN-HM2421	1	13,600 [4.0]	5,100 [1.5]	24,600 [7.2]	18.50	14.25	600 [283]	71	
			2	17,700 [5.2]	6,900 [2.0]				775 [366]	74	
			1 - dehumid	12,600 [3.7]	5,700 [1.7]				500 [236]	71	
			2 - dehumid	16,750 [4.9]	7,650 [2.2]				650 [307]	74	
	RCFN-H*2417A*	UGFD-06?MCK?	1	13,550 [4.0]	5,050 [1.5]	24,400 [7.1]	17.50	13.45	600 [283]	71	
			2	17,600 [5.2]	6,800 [2.0]				800 [378]	74	
		UGFD-07?MCK?	1	13,550 [4.0]	5,050 [1.5]	24,400 [7.1]	17.50	13.55	600 [283]	71	
			2	17,550 [5.1]	6,850 [2.0]				800 [378]	74	
		UGGD-06?MCK?	1	13,500 [4.0]	5,100 [1.5]	24,400 [7.1]	18.00	13.80	600 [283]	71	
			2	17,550 [5.1]	6,850 [2.0]				800 [378]	74	
		UGGD-07?MCK?	1	13,500 [4.0]	5,100 [1.5]	24,400 [7.1]	17.50	13.65	625 [295]	71	
			2	17,550 [5.1]	6,850 [2.0]				800 [378]	74	
		UGJD-06?MCK?	1	13,500 [4.0]	5,100 [1.5]	24,400 [7.1]	18.00	13.80	600 [283]	71	
			2	17,550 [5.1]	6,850 [2.0]				800 [378]	74	
		UGJD-07?MCK?	1	13,500 [4.0]	5,100 [1.5]	24,400 [7.1]	17.50	13.65	625 [295]	71	
			2	17,550 [5.1]	6,850 [2.0]				800 [378]	74	
		UGLR-07?AMK?	1	13,600 [4.0]	5,100 [1.5]	24,600 [7.2]	18.00	13.95	600 [283]	71	
			2	17,700 [5.2]	6,900 [2.0]				800 [378]	74	
		UGPR-05?BMK?	1	13,550 [4.0]	5,050 [1.5]	24,400 [7.1]	17.50	13.75	600 [283]	71	
			2	17,550 [5.1]	6,850 [2.0]				775 [366]	74	
		UGPR-07?AMK?	1	13,600 [4.0]	5,100 [1.5]	24,400 [7.1]	18.00	13.85	600 [283]	71	
			2	17,550 [5.1]	6,850 [2.0]				800 [378]	74	
		RCFN-H*2417A*+RXMD-C06	Coil Only	1	13,150 [3.9]	4,950 [1.5]	24,000 [7.0]	15.50	12.50	600 [283]	71
				2	17,300 [5.1]	6,700 [2.0]				775 [366]	74
	RCFN-H*2421A*	UGFD-06?MCK?	1	13,550 [4.0]	5,050 [1.5]	24,400 [7.1]	17.50	13.45	600 [283]	71	
			2	17,550 [5.1]	6,850 [2.0]				800 [378]	74	
		UGFD-07?MCK?	1	13,550 [4.0]	5,050 [1.5]	24,400 [7.1]	17.50	13.60	600 [283]	71	
			2	17,550 [5.1]	6,850 [2.0]				800 [378]	74	
		UGGD-06?MCK?	1	13,500 [4.0]	5,100 [1.5]	24,400 [7.1]	18.00	13.80	600 [283]	71	
			2	17,550 [5.1]	6,850 [2.0]				800 [378]	74	
		UGGD-07?MCK?	1	13,500 [4.0]	5,100 [1.5]	24,400 [7.1]	17.50	13.70	625 [295]	71	
			2	17,550 [5.1]	6,850 [2.0]				800 [378]	74	
		UGJD-06?MCK?	1	13,500 [4.0]	5,100 [1.5]	24,400 [7.1]	18.00	13.80	600 [283]	71	
			2	17,550 [5.1]	6,850 [2.0]				800 [378]	74	
		UGJD-07?MCK?	1	13,500 [4.0]	5,100 [1.5]	24,400 [7.1]	17.50	13.70	625 [295]	71	
			2	17,550 [5.1]	6,850 [2.0]				800 [378]	74	
		UGLR-07?AMK?	1	13,600 [4.0]	5,100 [1.5]	24,600 [7.2]	18.00	14.00	600 [283]	71	
			2	17,700 [5.2]	6,900 [2.0]				800 [378]	74	
		UGPR-05?BMK?	1	13,550 [4.0]	5,050 [1.5]	24,400 [7.1]	17.50	13.75	600 [283]	71	
			2	17,550 [5.1]	6,850 [2.0]				775 [366]	74	
		UGPR-07?AMK?	1	13,600 [4.0]	5,100 [1.5]	24,400 [7.1]	18.00	13.90	600 [283]	71	
			2	17,550 [5.1]	6,850 [2.0]				800 [378]	74	
		RCFN-H*2421A*+RXMD-C06	Coil Only	1	13,150 [3.9]	4,950 [1.5]	24,000 [7.0]	15.50	12.50	600 [283]	71
				2	17,300 [5.1]	6,700 [2.0]				775 [366]	74

[] Designates Metric Conversions

Performance Data @ ARI Standard Conditions—Cooling

Outdoor Unit UASL-	Model Numbers		Stage	ARI Cooling Performance 80°F [26.5°C] DB / 67°F [19.5°C] WB Indoor Air 95°F [35°C] DB Outdoor Air							
				Net Sensible BTU/H [kW]	Net Latent BTU/H [kW]	ARI Ratings			Indoor Airflow CFM [L/s]	Sound Rating db	
	ID Coil	ID Air Mover				Total Capacity BTU/H [kW]	SEER	EER			
036JEZ	RCQD-3624A*	UBHN-24J*	1	19,900 [5.8]	6,300 [1.8]	37,600 [11.0]	18.00	13.45	925 [437]	69	
			2	27,700 [8.1]	9,900 [2.9]				1150 [543]	72	
			1 - dehumid	20,050 [5.9]	6,550 [1.9]				800 [378]	69	
			2 - dehumid	26,050 [7.6]	10,550 [3.1]				975 [460]	72	
	RCFM-H*3617A*	UGFD-06?MCK?	1	18,450 [5.4]	6,550 [1.9]	35,000 [10.3]	14.50	11.55	875 [413]	69	
			2	24,800 [7.3]	10,200 [3.0]				1175 [554]	72	
		UGFD-07?MCK?	1	18,600 [5.4]	6,600 [1.9]	35,200 [10.3]	15.00	11.50	900 [425]	69	
			2	24,950 [7.3]	10,250 [3.0]				1200 [566]	72	
		UGGD-06?MCK?	1	18,750 [5.5]	6,650 [1.9]	35,400 [10.4]	15.00	11.70	900 [425]	69	
			2	25,100 [7.4]	10,300 [3.0]				1225 [578]	72	
		UGGD-07?MCK?	1	18,600 [5.4]	6,600 [1.9]	35,400 [10.4]	15.00	11.60	925 [437]	69	
			2	25,100 [7.4]	10,300 [3.0]				1225 [578]	72	
		UGJD-06?MCK?	1	18,750 [5.5]	6,650 [1.9]	35,400 [10.4]	15.00	11.70	900 [425]	69	
			2	25,100 [7.4]	10,300 [3.0]				1225 [578]	72	
		UGJD-07?MCK?	1	18,600 [5.4]	6,600 [1.9]	35,400 [10.4]	15.00	11.60	925 [437]	69	
			2	25,100 [7.4]	10,300 [3.0]				1225 [578]	72	
		UGLR-07?AMK?	1	18,750 [5.5]	6,650 [1.9]	35,600 [10.4]	15.50	12.15	925 [437]	69	
			2	25,250 [7.4]	10,350 [3.0]				1200 [566]	72	
		UGPR-05?BMK?	1	18,600 [5.4]	6,600 [1.9]	35,200 [10.3]	15.00	11.65	900 [425]	69	
			2	24,950 [7.3]	10,250 [3.0]				1200 [566]	72	
		UGPR-07?AMK?	1	18,750 [5.5]	6,650 [1.9]	35,600 [10.4]	15.50	12.10	900 [425]	69	
			2	25,250 [7.4]	10,350 [3.0]				1200 [566]	72	
		RCFM-H*3617A*+RXMD-C06	Coil Only	1	18,300 [5.4]	6,500 [1.9]	34,800 [10.2]	14.00	11.75	925 [437]	69
				2	25,100 [7.4]	9,700 [2.8]				1075 [507]	72
	RCFM-H*3621A*	UGFD-06?MCK?	1	18,450 [5.4]	6,550 [1.9]	35,000 [10.3]	14.50	11.60	875 [413]	69	
			2	24,800 [7.3]	10,200 [3.0]				1175 [554]	72	
		UGFD-07?MCK?	1	18,600 [5.4]	6,600 [1.9]	35,200 [10.3]	15.00	11.55	900 [425]	69	
			2	24,950 [7.3]	10,250 [3.0]				1200 [566]	72	
		UGFD-09?ZCM?	1	18,400 [5.4]	6,600 [1.9]	35,600 [10.4]	15.50	12.50	850 [401]	69	
			2	25,250 [7.4]	10,350 [3.0]				1150 [543]	72	
		UGFD-10?ZCM?	1	18,450 [5.4]	6,550 [1.9]	35,400 [10.4]	15.50	12.30	850 [401]	69	
			2	25,050 [7.3]	10,350 [3.0]				1175 [554]	72	
		UGGD-06?MCK?	1	18,750 [5.5]	6,650 [1.9]	35,600 [10.4]	15.00	11.85	900 [425]	69	
			2	25,250 [7.4]	10,350 [3.0]				1225 [578]	72	
		UGGD-07?MCK?	1	18,550 [5.4]	6,650 [1.9]	35,400 [10.4]	15.00	11.65	925 [437]	69	
			2	25,100 [7.4]	10,300 [3.0]				1225 [578]	72	
		UGGD-09?ZCM?	1	18,450 [5.4]	6,550 [1.9]	35,600 [10.4]	15.50	12.45	800 [378]	69	
			2	25,250 [7.4]	10,350 [3.0]				1175 [554]	72	
		UGGD-10?ZCM?	1	18,450 [5.4]	6,550 [1.9]	35,600 [10.4]	15.50	12.50	825 [389]	69	
			2	25,250 [7.4]	10,350 [3.0]				1175 [554]	72	
		UGJD-06?MCK?	1	18,750 [5.5]	6,650 [1.9]	35,600 [10.4]	15.00	11.80	900 [425]	69	
			2	25,250 [7.4]	10,350 [3.0]				1225 [578]	72	
		UGJD-07?MCK?	1	18,550 [5.4]	6,650 [1.9]	35,400 [10.4]	15.00	11.65	925 [437]	69	
			2	25,100 [7.4]	10,300 [3.0]				1225 [578]	72	
		UGJD-09?ZCM?	1	18,450 [5.4]	6,550 [1.9]	35,600 [10.4]	15.50	12.45	800 [378]	69	
			2	25,250 [7.4]	10,350 [3.0]				1175 [554]	72	
		UGJD-10?ZCM?	1	18,450 [5.4]	6,550 [1.9]	35,600 [10.4]	15.50	12.50	825 [389]	69	
			2	25,250 [7.4]	10,350 [3.0]				1175 [554]	72	
		UGLR-07?AMK?	1	18,750 [5.5]	6,650 [1.9]	35,600 [10.4]	15.50	12.20	925 [437]	69	
			2	25,200 [7.4]	10,400 [3.0]				1200 [566]	72	
		UGLR-10?BRM?	1	18,700 [5.5]	6,700 [2.0]	36,000 [10.5]	16.00	12.70	925 [437]	69	
			2	25,550 [7.5]	10,450 [3.1]				1200 [566]	72	

[] Designates Metric Conversions

Performance Data @ ARI Standard Conditions—Cooling

Outdoor Unit UASL-	Model Numbers		Stage	ARI Cooling Performance 80°F [26.5°C] DB / 67°F [19.5°C] WB Indoor Air 95°F [35°C] DB Outdoor Air							
				Net Sensible BTU/H [kW]	Net Latent BTU/H [kW]	ARI Ratings			Indoor Airflow CFM [L/s]	Sound Rating db	
	Total Capacity BTU/H [kW]	SEER				EER					
	ID Coil	ID Air Mover									
036JEZ	RCFM-H*3621A*	UGPR-05?BMK?	1	18,600 [5.4]	6,600 [1.9]	35,400 [10.4]	15.00	11.70	900 [425]	69	
			2	25,100 [7.4]	10,300 [3.0]				1200 [566]	72	
		UGPR-07?AMK?	1	18,750 [5.5]	6,650 [1.9]	35,600 [10.4]	15.50	12.15	900 [425]	69	
			2	25,200 [7.4]	10,400 [3.0]				1200 [566]	72	
		UGPR-07?BRQ?	1	18,550 [5.4]	6,650 [1.9]	36,000 [10.5]	16.00	12.70	875 [413]	69	
			2	25,500 [7.5]	10,500 [3.1]				1200 [566]	72	
		UGPR-10?BRM?	1	18,750 [5.5]	6,650 [1.9]	36,000 [10.5]	15.50	12.50	925 [437]	69	
			2	25,550 [7.5]	10,450 [3.1]				1225 [578]	72	
		RCFM-H*3621A*+RXMD-C06	Coil Only	1	18,300 [5.4]	6,500 [1.9]	35,200 [10.3]	14.00	11.80	925 [437]	69
				2	24,950 [7.3]	10,250 [3.0]				1150 [543]	72
	RCFM-H*4821A*	UGFD-06?MCK?	1	19,300 [5.7]	6,300 [1.8]	36,200 [10.6]	15.50	12.05	875 [413]	69	
			2	26,200 [7.7]	10,000 [2.9]				1175 [554]	72	
		UGFD-07?MCK?	1	19,450 [5.7]	6,350 [1.9]	36,400 [10.7]	15.50	12.05	900 [425]	69	
			2	26,350 [7.7]	10,050 [2.9]				1200 [566]	72	
		UGFD-09?ZCM?	1	19,450 [5.7]	6,350 [1.9]	36,800 [10.8]	16.00	12.95	850 [401]	69	
			2	26,650 [7.8]	10,150 [3.0]				1150 [543]	72	
		UGFD-10?ZCM?	1	19,450 [5.7]	6,350 [1.9]	36,600 [10.7]	16.00	12.75	850 [401]	69	
			2	26,500 [7.8]	10,100 [3.0]				1175 [554]	72	
		UGGD-06?MCK?	1	19,600 [5.7]	6,400 [1.9]	36,800 [10.8]	16.00	12.35	900 [425]	69	
			2	26,650 [7.8]	10,150 [3.0]				1225 [578]	72	
		UGGD-07?MCK?	1	19,600 [5.7]	6,400 [1.9]	36,600 [10.7]	15.50	12.10	925 [437]	69	
			2	26,500 [7.8]	10,100 [3.0]				1225 [578]	72	
		UGGD-09?ZCM?	1	19,300 [5.7]	6,300 [1.8]	36,600 [10.7]	16.50	12.90	800 [378]	69	
			2	26,450 [7.7]	10,150 [3.0]				1175 [554]	72	
		UGGD-10?ZCM?	1	19,300 [5.7]	6,300 [1.8]	36,800 [10.8]	16.50	12.95	825 [389]	69	
			2	26,650 [7.8]	10,150 [3.0]				1175 [554]	72	
		UGJD-06?MCK?	1	19,600 [5.7]	6,400 [1.9]	36,600 [10.7]	16.00	12.25	900 [425]	69	
			2	26,450 [7.7]	10,150 [3.0]				1225 [578]	72	
		UGJD-07?MCK?	1	19,600 [5.7]	6,400 [1.9]	36,600 [10.7]	15.50	12.15	925 [437]	69	
			2	26,500 [7.8]	10,100 [3.0]				1225 [578]	72	
		UGJD-09?ZCM?	1	19,300 [5.7]	6,300 [1.8]	36,800 [10.8]	16.50	12.95	800 [378]	69	
			2	26,650 [7.8]	10,150 [3.0]				1175 [554]	72	
		UGJD-10?ZCM?	1	19,300 [5.7]	6,300 [1.8]	36,800 [10.8]	16.50	12.95	825 [389]	69	
			2	26,650 [7.8]	10,150 [3.0]				1175 [554]	72	
		UGLR-07?AMK?	1	19,600 [5.7]	6,400 [1.9]	36,800 [10.8]	16.00	12.65	925 [437]	69	
			2	26,650 [7.8]	10,150 [3.0]				1200 [566]	72	
		UGLR-10?BRM?	1	19,750 [5.8]	6,450 [1.9]	37,000 [10.8]	16.50	13.15	925 [437]	69	
			2	26,750 [7.8]	10,250 [3.0]				1200 [566]	72	
		UGPR-05?BMK?	1	19,450 [5.7]	6,350 [1.9]	36,400 [10.7]	15.50	12.15	900 [425]	69	
			2	26,350 [7.7]	10,050 [2.9]				1200 [566]	72	
		UGPR-07?AMK?	1	19,600 [5.7]	6,400 [1.9]	36,800 [10.8]	16.00	12.65	900 [425]	69	
			2	26,650 [7.8]	10,150 [3.0]				1200 [566]	72	
		UGPR-07?BRQ?	1	19,600 [5.7]	6,400 [1.9]	37,200 [10.9]	16.50	13.20	875 [413]	69	
			2	26,950 [7.9]	10,250 [3.0]				1200 [566]	72	
		UGPR-10?BRM?	1	19,600 [5.7]	6,400 [1.9]	37,200 [10.9]	16.50	13.00	925 [437]	69	
			2	26,950 [7.9]	10,250 [3.0]				1225 [578]	72	
		RCFM-H*4821A*+RXMD-C06	Coil Only	1	19,150 [5.6]	6,250 [1.8]	36,200 [10.6]	14.50	12.10	925 [437]	69
				2	26,200 [7.7]	10,000 [2.9]				1150 [543]	72

[] Designates Metric Conversions

Performance Data @ ARI Standard Conditions—Cooling

Outdoor Unit UASL-	Model Numbers		Stage	ARI Cooling Performance 80°F [26.5°C] DB / 67°F [19.5°C] WB Indoor Air 95°F [35°C] DB Outdoor Air						
				Net Sensible BTU/H [kW]	Net Latent BTU/H [kW]	ARI Ratings			Indoor Airflow CFM [L/s]	Sound Rating db
	ID Coil	ID Air Mover				Total Capacity BTU/H [kW]	SEER	EER		
036JEZ	RCFM-H*4824A*	UGFD-09?ZCM?	1	19,450 [5.7]	6,350 [1.9]	36,800 [10.8]	16.00	12.95	850 [401]	69
			2	26,650 [7.8]	10,150 [3.0]				1150 [543]	72
		UGFD-10?ZCM?	1	19,450 [5.7]	6,350 [1.9]	36,600 [10.7]	16.00	12.75	850 [401]	69
			2	26,500 [7.8]	10,100 [3.0]				1175 [554]	72
		UGFD-12?RCM?	1	19,800 [5.8]	6,400 [1.9]	37,200 [10.9]	16.50	13.00	900 [425]	69
			2	26,950 [7.9]	10,250 [3.0]				1225 [578]	72
		UGGD-09?ZCM?	1	19,300 [5.7]	6,300 [1.8]	36,800 [10.8]	16.50	13.00	800 [378]	69
			2	26,650 [7.8]	10,150 [3.0]				1175 [554]	72
		UGGD-10?ZCM?	1	19,300 [5.7]	6,300 [1.8]	36,800 [10.8]	16.50	12.95	825 [389]	69
			2	26,650 [7.8]	10,150 [3.0]				1175 [554]	72
		UGGD-12?RCM?	1	19,750 [5.8]	6,450 [1.9]	37,200 [10.9]	16.50	13.10	900 [425]	69
			2	26,950 [7.9]	10,250 [3.0]				1225 [578]	72
		UGJD-09?ZCM?	1	19,300 [5.7]	6,300 [1.8]	36,800 [10.8]	16.50	12.95	800 [378]	69
			2	26,650 [7.8]	10,150 [3.0]				1175 [554]	72
		UGJD-10?ZCM?	1	19,300 [5.7]	6,300 [1.8]	36,800 [10.8]	16.50	12.95	825 [389]	69
			2	26,650 [7.8]	10,150 [3.0]				1175 [554]	72
		UGLR-10?BRM?	1	19,750 [5.8]	6,450 [1.9]	37,000 [10.8]	16.50	13.15	925 [437]	69
			2	26,750 [7.8]	10,250 [3.0]				1200 [566]	72
		UGLR-12?ARM?	1	20,050 [5.9]	6,550 [1.9]	37,200 [10.9]	16.50	13.25	1000 [472]	69
			2	26,900 [7.9]	10,300 [3.0]				1225 [578]	72
		UGPR-07?BRQ?	1	19,600 [5.7]	6,400 [1.9]	37,200 [10.9]	16.50	13.20	875 [413]	69
			2	26,950 [7.9]	10,250 [3.0]				1200 [566]	72
		UGPR-10?BRM?	1	19,600 [5.7]	6,400 [1.9]	37,200 [10.9]	16.50	13.00	925 [437]	69
			2	26,950 [7.9]	10,250 [3.0]				1225 [578]	72
	RCFM-H*4824A*+RXMD-C06	Coil Only	1	19,150 [5.6]	6,250 [1.8]	36,200 [10.6]	14.50	12.10	925 [437]	69
			2	26,200 [7.7]	10,000 [2.9]				1150 [543]	72
	RCHL-36A*	UGFD-06?MCK?	1	17,450 [5.1]	6,950 [2.0]	34,200 [10.0]	14.85	11.60	875 [413]	69
			2	23,600 [6.9]	10,600 [3.1]				1175 [554]	72
		UGFD-07?MCK?	1	17,750 [5.2]	7,050 [2.1]	34,400 [10.1]	15.05	11.60	900 [425]	69
			2	23,700 [6.9]	10,700 [3.1]				1200 [566]	72
		UGFD-09?ZCM?	1	17,600 [5.2]	7,000 [2.1]	34,800 [10.2]	15.75	12.50	850 [401]	69
			2	24,000 [7.0]	10,800 [3.2]				1150 [543]	72
		UGFD-10?ZCM?	1	17,600 [5.2]	7,000 [2.1]	34,600 [10.1]	15.65	12.30	850 [401]	69
			2	23,850 [7.0]	10,750 [3.1]				1175 [554]	72
		UGFD-12?RCM?	1	17,900 [5.2]	7,100 [2.1]	35,200 [10.3]	15.50	12.50	900 [425]	69
			2	24,300 [7.1]	10,900 [3.2]				1225 [578]	72
		UGGD-06?MCK?	1	17,750 [5.2]	7,050 [2.1]	34,800 [10.2]	15.35	11.95	900 [425]	69
			2	24,000 [7.0]	10,800 [3.2]				1225 [578]	72
		UGGD-07?MCK?	1	17,750 [5.2]	7,050 [2.1]	34,600 [10.1]	15.20	11.70	925 [437]	69
			2	23,850 [7.0]	10,750 [3.1]				1225 [578]	72
		UGGD-09?ZCM?	1	17,450 [5.1]	6,950 [2.0]	34,800 [10.2]	15.80	12.50	800 [378]	69
			2	24,000 [7.0]	10,800 [3.2]				1175 [554]	72
		UGGD-10?ZCM?	1	17,600 [5.2]	7,000 [2.1]	34,800 [10.2]	15.80	12.50	825 [389]	69
			2	24,000 [7.0]	10,800 [3.2]				1175 [554]	72
		UGGD-12?RCM?	1	17,900 [5.2]	7,100 [2.1]	35,200 [10.3]	16.00	12.70	900 [425]	69
			2	24,250 [7.1]	10,950 [3.2]				1225 [578]	72
		UGJD-06?MCK?	1	17,750 [5.2]	7,050 [2.1]	34,800 [10.2]	15.00	11.85	900 [425]	69
			2	24,050 [7.0]	10,750 [3.1]				1225 [578]	72
UGJD-07?MCK?		1	17,750 [5.2]	7,050 [2.1]	34,600 [10.1]	15.00	11.70	925 [437]	69	
		2	23,850 [7.0]	10,750 [3.1]				1225 [578]	72	
UGJD-09?ZCM?	1	17,450 [5.1]	6,950 [2.0]	34,800 [10.2]	15.50	12.50	800 [378]	69		
	2	24,000 [7.0]	10,800 [3.2]				1175 [554]	72		

[] Designates Metric Conversions

Performance Data @ ARI Standard Conditions—Cooling

Outdoor Unit UASL-	Model Numbers		Stage	ARI Cooling Performance 80°F [26.5°C] DB / 67°F [19.5°C] WB Indoor Air 95°F [35°C] DB Outdoor Air							
				Net Sensible BTU/H [kW]	Net Latent BTU/H [kW]	ARI Ratings			Indoor Airflow CFM [L/s]	Sound Rating db	
	ID Coil	ID Air Mover				Total Capacity BTU/H [kW]	SEER	EER			
036JEZ	RCHL-36A*	UGJD-10?ZCM?	1	17,600 [5.2]	7,000 [2.1]	34,800 [10.2]	15.50	12.50	825 [389]	69	
			2	24,000 [7.0]	10,800 [3.2]				1175 [554]	72	
		UGLR-07?AMK?	1	17,900 [5.2]	7,100 [2.1]	34,800 [10.2]	15.50	12.25	925 [437]	69	
			2	24,000 [7.0]	10,800 [3.2]				1200 [566]	72	
		UGLR-10?BRM?	1	17,900 [5.2]	7,100 [2.1]	35,200 [10.3]	16.00	12.70	925 [437]	69	
			2	24,300 [7.1]	10,900 [3.2]				1200 [566]	72	
		UGLR-12?ARM?	1	18,150 [5.3]	7,250 [2.1]	35,400 [10.4]	16.00	12.80	1000 [472]	69	
			2	24,450 [7.2]	10,950 [3.2]				1225 [578]	72	
		UGPR-05?BMK?	1	17,550 [5.1]	7,050 [2.1]	34,600 [10.1]	15.00	11.70	900 [425]	69	
			2	23,900 [7.0]	10,700 [3.1]				1200 [566]	72	
		UGPR-07?AMK?	1	17,700 [5.2]	7,100 [2.1]	34,800 [10.2]	15.50	12.20	900 [425]	69	
			2	24,000 [7.0]	10,800 [3.2]				1200 [566]	72	
		UGPR-07?BRQ?	1	17,750 [5.2]	7,050 [2.1]	35,200 [10.3]	16.00	12.70	875 [413]	69	
			2	24,300 [7.1]	10,900 [3.2]				1200 [566]	72	
		UGPR-10?BRM?	1	17,900 [5.2]	7,100 [2.1]	35,200 [10.3]	15.50	12.55	925 [437]	69	
			2	24,300 [7.1]	10,900 [3.2]				1225 [578]	72	
		RCHL-36A*+RXMD-C06	Coil Only	1	17,300 [5.1]	6,900 [2.0]	34,200 [10.0]	13.75	11.55	925 [437]	69
				2	23,600 [6.9]	10,600 [3.1]				1150 [543]	72
	RCQD-3621A*	UGFD-06?MCK?	1	19,450 [5.7]	6,150 [1.8]	36,600 [10.7]	16.05	12.00	875 [413]	69	
			2	26,950 [7.9]	9,650 [2.8]				1175 [554]	72	
		UGFD-07?MCK?	1	19,600 [5.7]	6,200 [1.8]	37,000 [10.8]	16.30	12.00	900 [425]	69	
			2	27,300 [8.0]	9,700 [2.8]				1200 [566]	72	
		UGFD-09?ZCM?	1	19,600 [5.7]	6,200 [1.8]	37,200 [10.9]	17.05	12.90	850 [401]	69	
			2	27,400 [8.0]	9,800 [2.9]				1150 [543]	72	
		UGFD-10?ZCM?	1	19,400 [5.7]	6,200 [1.8]	37,200 [10.9]	16.95	12.70	850 [401]	69	
			2	27,400 [8.0]	9,800 [2.9]				1175 [554]	72	
		UGJD-06?MCK?	1	19,750 [5.8]	6,250 [1.8]	37,200 [10.9]	16.50	12.25	900 [425]	69	
			2	27,400 [8.0]	9,800 [2.9]				1225 [578]	72	
		UGJD-07?MCK?	1	19,750 [5.8]	6,250 [1.8]	37,200 [10.9]	16.00	12.10	925 [437]	69	
			2	27,450 [8.0]	9,750 [2.9]				1225 [578]	72	
		UGJD-09?ZCM?	1	19,450 [5.7]	6,150 [1.8]	37,200 [10.9]	17.00	12.90	800 [378]	69	
			2	27,400 [8.0]	9,800 [2.9]				1175 [554]	72	
		UGJD-10?ZCM?	1	19,450 [5.7]	6,150 [1.8]	37,200 [10.9]	17.00	12.90	825 [389]	69	
			2	27,400 [8.0]	9,800 [2.9]				1175 [554]	72	
		UGPR-05?BMK?	1	19,600 [5.7]	6,200 [1.8]	37,000 [10.8]	16.00	12.10	900 [425]	69	
			2	27,250 [8.0]	9,750 [2.9]				1200 [566]	72	
		UGPR-07?AMK?	1	19,750 [5.8]	6,250 [1.8]	37,400 [11.0]	16.50	12.60	900 [425]	69	
			2	27,600 [8.1]	9,800 [2.9]				1200 [566]	72	
		UGPR-07?BRQ?	1	19,750 [5.8]	6,250 [1.8]	37,600 [11.0]	17.00	13.15	875 [413]	69	
			2	27,700 [8.1]	9,900 [2.9]				1200 [566]	72	
		UGPR-10?BRM?	1	19,750 [5.8]	6,250 [1.8]	37,600 [11.0]	17.00	12.95	925 [437]	69	
			2	27,700 [8.1]	9,900 [2.9]				1225 [578]	72	
RCQD-3621A*+RXMD-C06	Coil Only	1	19,300 [5.7]	6,100 [1.8]	36,600 [10.7]	15.00	12.05	925 [437]	69		
		2	26,950 [7.9]	9,650 [2.8]				1150 [543]	72		

[] Designates Metric Conversions

Performance Data @ ARI Standard Conditions—Cooling

Outdoor Unit UASL-	Model Numbers		Stage	ARI Cooling Performance 80°F [26.5°C] DB / 67°F [19.5°C] WB Indoor Air 95°F [35°C] DB Outdoor Air						
				Net Sensible BTU/H [kW]	Net Latent BTU/H [kW]	ARI Ratings			Indoor Airflow CFM [L/s]	Sound Rating db
	ID Coil	ID Air Mover				Total Capacity BTU/H [kW]	SEER	EER		
036JEZ	RCQD-3624A*	UGFD-09?ZCM?	1	19,600 [5.7]	6,200 [1.8]	37,200 [10.9]	17.05	12.95	850 [401]	69
			2	27,400 [8.0]	9,800 [2.9]				1150 [543]	72
		UGFD-10?ZCM?	1	19,400 [5.7]	6,200 [1.8]	37,200 [10.9]	16.95	12.80	850 [401]	69
			2	27,400 [8.0]	9,800 [2.9]				1175 [554]	72
		UGFD-12?RCM?	1	19,700 [5.8]	6,300 [1.8]	37,600 [11.0]	17.25	13.00	900 [425]	69
			2	27,700 [8.1]	9,900 [2.9]				1225 [578]	72
		UGJD-09?ZCM?	1	19,450 [5.7]	6,150 [1.8]	37,200 [10.9]	17.00	12.95	800 [378]	69
			2	27,400 [8.0]	9,800 [2.9]				1175 [554]	72
		UGJD-10?ZCM?	1	19,450 [5.7]	6,150 [1.8]	37,200 [10.9]	17.00	12.95	825 [389]	69
			2	27,400 [8.0]	9,800 [2.9]				1175 [554]	72
		UGPR-07?BRQ?	1	19,750 [5.8]	6,250 [1.8]	37,600 [11.0]	17.00	13.20	875 [413]	69
			2	27,700 [8.1]	9,900 [2.9]				1200 [566]	72
		UGPR-10?BRM?	1	19,750 [5.8]	6,250 [1.8]	37,600 [11.0]	17.00	13.05	925 [437]	69
			2	27,700 [8.1]	9,900 [2.9]				1225 [578]	72
	RCQD-3624A*+RXMD-C06	Coil Only	1	19,300 [5.7]	6,100 [1.8]	36,600 [10.7]	15.00	12.05	925 [437]	69
			2	26,950 [7.9]	9,650 [2.8]				1150 [543]	72
	RCSM-H*3621A*	UHPL-HM3621	1	18,900 [5.5]	6,700 [2.0]	36,200 [10.6]	16.00	12.80	925 [437]	69
			2	25,650 [7.5]	10,550 [3.1]				1225 [578]	72

[] Designates Metric Conversions

Electrical and Physical Data

Model Number UASL-	ELECTRICAL						PHYSICAL						
	Phase Frequency (Hz) Voltage (Volts)	Compressor		Fan Motor Full Load Amperes (FLA)	Min. Circuit Ampacity Amperes	Fuse or HACR Circuit Breaker		Outdoor Coil			Refrig. Per Circuit Oz. [g]	Weight	
		Rated Load Amperes (RLA)	Locked Rotor Amperes (LRA)			Min. Amperes	Max. Amperes	Face Area Sq. Ft. [m ²]	No. Rows	CFM [L/s]		Net Lbs. [kg]	Shipping Lbs. [kg]
024JEZ	1-60-208/230	10.3/10.3	52	0.5	14/14	20/20	20/20	15.80 [1.47]	1	2200/2500 [1038/1180]	144 [4082]	236 [107]	246 [111.6]
036JEZ	1-60-208/230	16.7/16.7	82	2.8	24/24	30/30	40/40	23.01 [2.14]	1	2800/3400 [1321/1604]	150 [4252]	236 [107]	246 [111.6]

Unit Dimensions

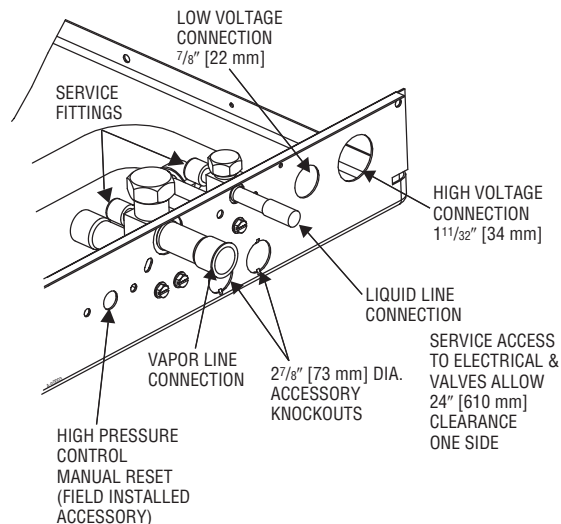
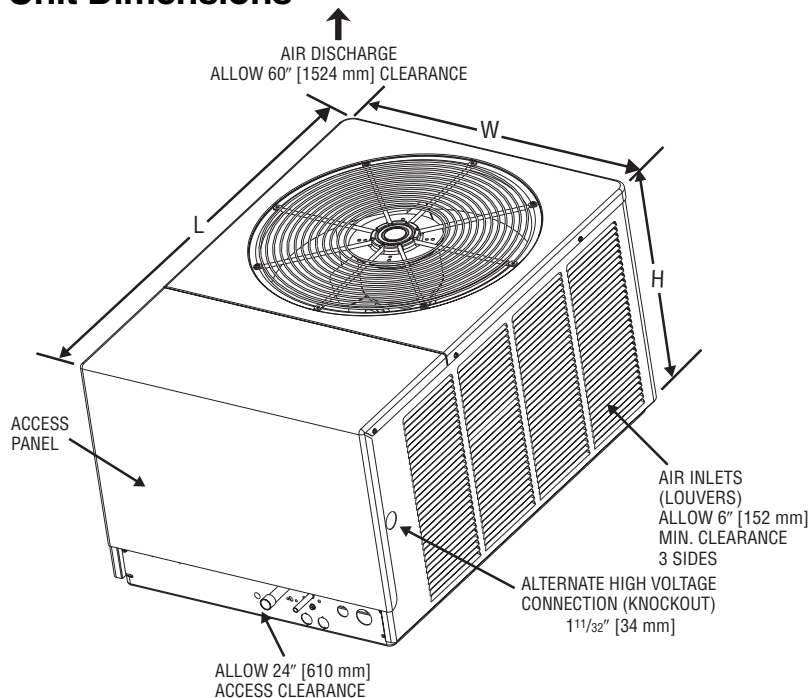

Model Number UASL-	Height "H" (Inches) [mm]	Length "L" (Inches) [mm]	Width "W" (Inches) [mm]
024JEZ/036JEZ	33 [838]	44 ³ / ₈ [1127]	31 ¹ / ₂ [800]

[] Designates Metric Conversions

GENERAL TERMS OF LIMITED WARRANTY

Ruud will furnish a replacement for any part of this product which fails in normal use and service within the applicable period stated, in accordance with the terms of the limited warranty.

For Complete Details of the Limited Warranty, Including Applicable Terms and Conditions, See Your Local Installer or Contact the Manufacturer for a Copy.

Limited Parts Warranty:

Ruud *Ultra Series™* equipment features a 10-year limited parts warranty.*

*This ten-year limited parts warranty is applicable only to single-phase products installed in residential applications.

UASL- JEZ Conditional Replacement Warranty:

Ruud will provide a replacement model (if an exact replacement is not available, an equivalent product will be provided) to the original purchaser if the compressor fails within 10 years (providing the unit is installed with a new Ruud *Ultra Series™* Air Handler OR Ruud Indoor Coil with a Ruud *Ultra Series™* Gas Furnace, and is properly matched as specified by Ruud and/or listed in the Air Conditioning Institute (ARI) published rating, and if additional conditions are satisfied. See product warranty card for additional information.

BEFORE PURCHASING THIS APPLIANCE, READ IMPORTANT ENERGY COST AND EFFICIENCY INFORMATION AVAILABLE FROM YOUR RETAILER.

Condensing Unit Refrigerant Line Size Information

Liquid Line Sizing (2-Stage R-410A)														
System Capacity (2nd Stage)	Liquid Line Connection Size (Inch I.D.) [mm]	Line Size (Inch O.D.) [mm]	Liquid Line Size Outdoor Unit above Indoor Coil (Cooling Only)						Liquid Line Size Outdoor Unit Below Indoor Coil					
			Total Equivalent Length—Feet [m]						Total Equivalent Length—Feet [m]					
			25 [7.62]	50 [15.24]	75 [22.86]	100 [30.48]	125 [38.10]	150 [45.72]	25 [7.62]	50 [15.24]	75 [22.86]	100 [30.48]	125 [38.10]	150 [45.72]
			Minimum Vertical Separation—Feet [m]						Maximum Vertical Separation—Feet [m]					
2 Ton	3/8" [9.53]	1/4* [7.94]	0	0	17 [5.18]	43 [13.11]	70 [21.34]	95 [28.96]	25 [7.62]	10 [3.05]	N/A	N/A	N/A	N/A
		5/16 [7.94]	0	0	0	0	0	0	25 [7.62]	50 [15.24]	40 [12.19]	35 [10.67]	29 [8.84]	22 [6.71]
		3/8* [9.53]	0	0	0	0	0	0	25 [7.62]	50 [15.24]	45 [13.72]	42 [12.80]	39 [11.89]	37 [11.28]
3 Ton	3/8" [9.53]	5/16 [7.94]	0	0	0	0	0	7 [2.13]	25 [7.62]	39 [11.89]	28 [8.53]	16 [4.88]	5 [1.52]	N/A
		3/8* [9.53]	0	0	0	0	0	0	25 [7.62]	50 [15.24]	51 [15.54]	48 [14.63]	44 [13.41]	40 [12.19]

NOTES:

* Standard line size.

N/A = Application not recommended.

Suction Line Length/Size versus Capacity Multiplier (2-Stage R-410A)			
Unit Size		2 Ton	3 Ton
Suction Line Connection Size		3/4" [19.05] I.D.	3/4" [19.05] I.D.
Suction Line Run Feet [m]		5/8" [15.88 mm] O.D. Optional 3/4" [19.05 mm] O.D. Standard	5/8" [15.88 mm] O.D. Optional 3/4" [19.05 mm] O.D. Standard
25' [7.62]	Optional	—	.99
	Standard	1.00	1.00
	Optional	1.00	—
50' [15.24]	Optional	—	.98
	Standard	.99	.99
	Optional	1.00	—
100' [30.48]	Optional	—	.95
	Standard	.97	.97
	Optional	.98	—
150' [45.72]	Optional	—	.91
	Standard	.95	.95
	Optional	.97	—

Note: Using suction line larger than shown in chart will result in poor oil return.

[] Designates Metric Conversions

Before proceeding with installation, refer to installation instructions packaged with each model, as well as complying with all Federal, State, Provincial, and Local codes, regulations, and practices.

**Ruud Heating,
Cooling and
Water Heating**

P.O. Box 17010, Fort Smith, AR 72917



"In keeping with its policy of continuous progress and product improvement, Ruud reserves the right to make changes without notice."