

HEAT PUMPS

UPNL-

13 SEER Models
Nominal Sizes 1 1/2 to 5 Tons
[5.28 kW] to [17.6 kW]

Seven Models

Cooling Capacities
18,200 to 60,500 BTU/HR
[5.33 kW] to [17.73 kW]

R-410A
Eco-friendly refrigerant

RUUD
ACHIEVER
Series



The Ruud *Achiever*® Series UPNL- Heat Pump Outdoor units can provide year-round heating and cooling comfort for residential, multi-family and light commercial applications. They are designed to operate with Ruud indoor units with cooling and heating capacities certified under the ARI Certification program.

The following additional features, plus its energy-saving characteristics, make the UPNL- Heat Pump outdoor units an excellent choice for new construction or upgrading your present system.

- Attractive, louvered wrap around jacket protects coil from weather extremes and yard hazards. Top grille is steel reinforced for extra strength. Cabinet is powder painted for all weather protection.
- Four sided outdoor coil design allows compressor operation with access panel removed.
- Air is discharged upward away from bushes and shrubs. The discharge pattern of the top grille provides minimum air restriction, resulting in quiet fan operation.
- Combination Grille/Motor Mount secures the fan motor to the underside of the discharge grille.
- All controls are accessible by removing one service panel. Removable top grille provides access to the outdoor fan motor and outdoor coil.
- Compressor compartment offers additional protection from the elements and reduces operating noise.
- Single speed, 8-pole fan motor is designed for quieter, energy-saving operation.
- Non-cycling reversing valve and demand defrost.
- All models meet or exceed a 1000-hour salt spray test per ASTM B117 Standard Practice for Operating Salt Spray Testing Apparatus.

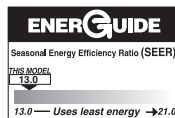

Engineering Features

UPNL- Series Heat Pump Outdoor Unit

- Scroll compressor** is hermetically sealed and incorporates internal high temperature motor overload protection, and durable insulation on the motor windings. It is externally mounted on rubber grommets to reduce vibration and noise.
- Copper Tube/Aluminum Fin Coils**—Both indoor and outdoor coils.
- Strong, Attractive Cabinet**—Constructed of powder painted steel. Louvered design protects the coil from damage.
- Internal Check Valve**—Provides for more quiet refrigerant metering.
- Enhanced Compressor Protection**—Features an **enhanced defrost control, auto-reset high pressure control, and auto-reset low pressure control** to provide compressor protection under abnormally high head pressure conditions (outdoor fan failure, restriction, dirty coil, etc.) or abnormally low suction pressure conditions (restrictions, TEV failure, loss of charge, indoor blower failure, etc.) while eliminating nuisance tripping sometimes experienced with conventional control systems.
- Drawn Painted Base Pan**—For extra corrosion resistance and sound reduction.
- Demand Defrost Control**—Provides complete defrost when defrost is required.
- Non-Cycling Reversing Valve**—Eliminates discharge noises on each heating cycle.
- Hot Gas Muffler**—Reduces noise in heating cycle.
- Bi-Directional Filter Drier**—Standard on UPNL- *AZ models (shipped – not installed).
- Service valves** are standard on all models.
- Refrigerant Metering**—TEV accurately meter refrigerant into indoor and outdoor coils.
- The **UPNL-** have a 10 year limited compressor warranty.
- All refrigerant connections are on the exterior of the unit, located close to the ground for neat appearing installations.
- Coil design permits compressor operation with the access panel removed.
- Control box is fully accessible in the upper part of the cabinet, just under the access panel.
- Power and control wiring are kept separate.
- Every unit is factory charged and tested.

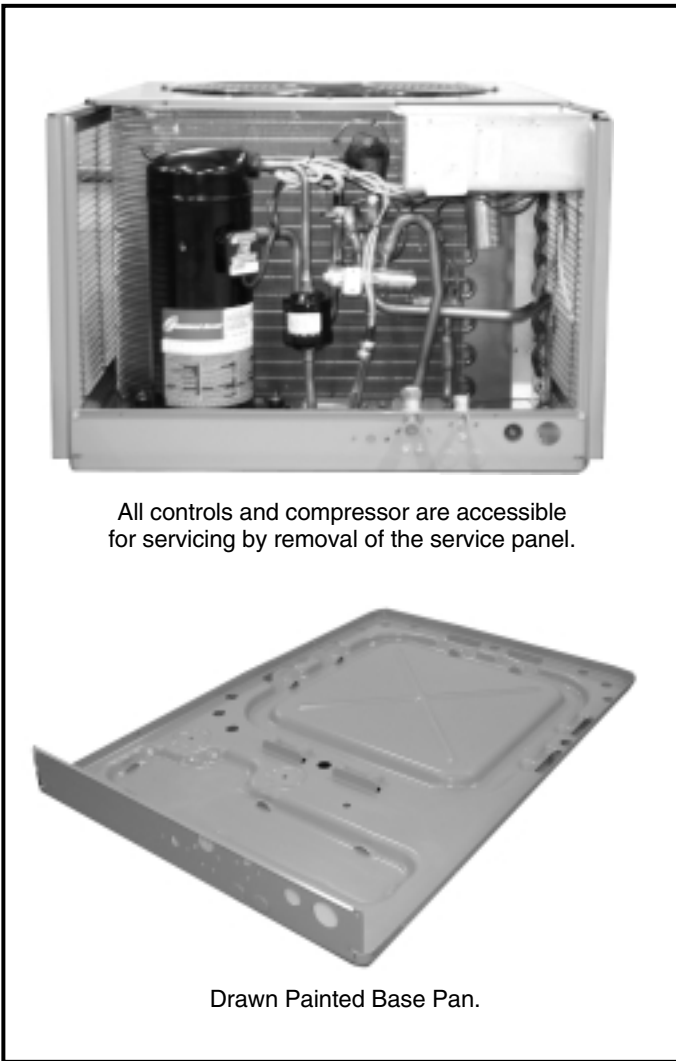

All controls and compressor are accessible for servicing by removal of the service panel.

Drawn Painted Base Pan.

Model Number Identification

<u>U</u>	<u>P</u>	<u>N</u>	<u>L</u>	<u>—</u>	<u>018</u>	<u>J</u>	<u>A</u>	<u>Z</u>
RUUD	REMOTE HEAT PUMP	N = 13 SEER	DESIGN SERIES L = R-410A		COOLING CAPACITY	ELECTRICAL DESIGNATION	VARIATIONS A SERIES = FULL-FEATURED	COOLING CONNECTION FITTING Z = SWEAT W/SCROLL
					018 = 18,000 BTU/HR [5.28 kW] 024 = 24,000 BTU/HR [7.03 kW] 030 = 30,000 BTU/HR [8.79 kW] 036 = 36,000 BTU/HR [10.55 kW] 042 = 42,000 BTU/HR [12.31 kW] 048 = 48,000 BTU/HR [14.07 kW] 060 = 60,000 BTU/HR [17.58 kW]	J = 208/230V-1-60 C = 208/230V-3-60 (RPNL 3, 3 1/2, 4 & 5 TON MODELS ONLY) D = 460V-3-60 (RPNL 3, 3 1/2, 4 & 5 TON MODELS ONLY) Y = 575V-3-60 (RPNL 4 & 5 TON MODELS ONLY)		

[] Designates Metric Conversions

Accessories

- **Low Ambient Control**—Allows low temperature operation in the cooling cycle down to 0°F [-17.8°C] outdoor temperature. It is recommended that this control be installed in units to be operated for cooling at outdoor ambient temperatures under 70°F [21°C]. (Model No. RXAD-A08)
- **Outdoor Thermostats**—
RXPT-A01—One outdoor thermostat in box.
RXPT-A02—One outdoor thermostat for mounting in box for use with RXPT-A01 or A03.
RXPT-A03—One outdoor thermostat with emergency Heat Relay wired and mounted in box.
RXPT-A04—Two outdoor thermostats with emergency Heat Relay wired and mounted in box.
- **Compressor Crankcase Heater**—Available through PROSTOCK®.
- **Heat Pump Monitor**—Indicates inefficient operation or malfunction of heat pump. (Model No. RXPM-B01)
- **Thermostats**—



300-Series *
Deluxe Programmable



200-Series *
Programmable



100-Series *
Non-Programmable

400-Series *
Special Applications/Programmable

Brand	Unique Model Number Prefix	Descriptor (3 Characters)	Series (3 Characters)	System (2 Characters)	Type (2 Characters)
UHC	-	TST	101	GE	MS
UHC=Ruud		TST=Thermostat	100=Non-Programmable	GE=Gas/Oil/Electric	SS=Single-Stage
			200=Programmable	HP=Heat Pump	MS=Multi-Stage
			300=Deluxe Programmable	MD=Modulating Furnace	
			400=Special Applications/Programmable	DF=Dual Fuel	
			UN=Universal AC/HP/GE		

* Photos are representative. Actual models may vary.

For detailed thermostat match-up information, see specification sheet form number T22-001.

Ruud Heat Pump System

For all season home comfort, performance and energy conservation, choose a Ruud UPNL- Series Heat Pump and a UHSL, UHLL, or UHKL Series Air Handler.

More than a reverse cycle air conditioner, it's a specially designed combination Winter/Summer comfort system using a single indoor coil for heating and cooling.

To choose an Air Handler designed for use with the UPNL- Heat Pumps, refer to the Performance Data Tables and/or the air handler specification sheet.

SCROLL COMPRESSOR

The scroll compressor is the key to efficiency for this Ruud model. It's the latest in high-efficiency compressor technology. The advanced scroll compressor offers low noise and vibration characteristics and features tolerance to liquid refrigerant and system contamination. The scroll compressor also has low start torque, eliminating start problems in the field. And its unique design enables the UPNL- heat pumps to perform efficiently, quietly and dependably.



- **Blower Time Delay Control** (RXMD-C04 is not required if the outdoor unit is matched with a Ruud furnace or air handler or if the furnace or air handler used has a blower off time delay built in.)
- **Fossil Fuel Kits**—RXPF-01
RXPF-02
- **Hard Start Components**—Offer additional starting torque to cover a wide range of voltage and pressure variations. Available through PROSTOCK®

Performance Data ARI Standard Conditions—UPNL-

Note: Only these combinations of indoor/outdoor units are approved and any other combinations should not be used.

Model Numbers		ARI Cooling Performance							ARI Heating Performance (70°F [21°C] Indoor)				
		80°F [26.5°C] DB/67°F [19.5°C] WB Indoor Air 95°F [35°C] DB Outdoor Air							Outdoor Air 47°F [8.5°C] DB/ 43°F [6°C] WB DOE High Temp.		Outdoor Air 17°F [-8.5°C] DB/ 15°F [-9.5°C] WB DOE Low Temp.		DOE Region IV HSPF
Outdoor Unit UPNL-	Indoor Coil and/or Air Handler	Total Capacity BTU/H [kW]	Net Sens. BTU/H [kW]	Net Latent BTU/H [kW]	EER	SEER	Snd. Rate dB	Indoor CFM [L/s]	BTU/H [kW]	COP	BTU/H [kW]	COP	
Revised 4/21/2008													
018JAZ	UHSL-HM1817 (RCSL-H*2417A*) ①	18,300 [5.4]	13,500 [4.0]	4,800 [1.4]	11.15	13.00	72	600 [283]	17,500 [5.1]	3.54	10,900 [3.2]	2.34	8.50
	RCFL-H*2414A*	18,200 [5.3]	13,400 [3.9]	4,800 [1.4]	10.75	13.00	72	600 [283]	17,700 [5.2]	3.46	11,100 [3.3]	2.30	8.20
	RCFL-H*2417A*	18,200 [5.3]	13,400 [3.9]	4,800 [1.4]	10.75	13.00	72	600 [283]	17,700 [5.2]	3.46	11,100 [3.3]	2.30	8.20
	RCFL-H*2417A* (UGFD-06?MCK?)	18,600 [5.4]	13,750 [4.0]	4,850 [1.4]	11.90	14.00	72	600 [283]	17,200 [5.0]	3.70	10,600 [3.1]	2.42	9.00
	RCFL-H*2417A* (UGFD-07?MCK?)	18,600 [5.4]	13,750 [4.0]	4,850 [1.4]	11.90	14.00	72	600 [283]	17,200 [5.0]	3.70	10,600 [3.1]	2.42	9.00
	RCFL-H*2417A* (UGGD-06?MCK?)	18,700 [5.5]	13,750 [4.0]	4,950 [1.5]	12.05	14.00	72	600 [283]	17,200 [5.0]	3.74	10,600 [3.1]	2.44	9.00
	RCFL-H*2417A* (UGGD-07?MCK?)	18,600 [5.4]	13,750 [4.0]	4,850 [1.4]	12.00	14.00	72	625 [295]	17,200 [5.0]	3.72	10,600 [3.1]	2.42	9.00
	RCFL-H*2417A* (UGJD-06?MCK?)	18,700 [5.5]	13,750 [4.0]	4,950 [1.5]	12.05	14.00	72	600 [283]	17,200 [5.0]	3.72	10,600 [3.1]	2.44	9.00
	RCFL-H*2417A* (UGJD-07?MCK?)	18,600 [5.4]	13,750 [4.0]	4,850 [1.4]	12.00	14.00	72	625 [295]	17,200 [5.0]	3.72	10,600 [3.1]	2.42	9.00
	RCFL-H*2417A* (UGLR-07?AMK?)	18,700 [5.5]	13,750 [4.0]	4,950 [1.5]	12.05	14.00	72	600 [283]	17,100 [5.0]	3.74	10,500 [3.1]	2.44	9.00
	RCFL-H*2417A* (UGPR-05?BMK?)	18,600 [5.4]	13,700 [4.0]	4,900 [1.4]	11.80	14.00	72	600 [283]	17,200 [5.0]	3.68	10,600 [3.1]	2.42	9.00
	RCFL-H*2417A* (UGPR-07?AMK?)	18,700 [5.5]	13,750 [4.0]	4,950 [1.5]	12.00	14.00	72	600 [283]	17,200 [5.0]	3.72	10,600 [3.1]	2.44	9.00
	17AHL24HM (RCSL-H*2417A*)	18,600 [5.4]	13,750 [4.0]	4,850 [1.4]	12.00	14.00	72	600 [283]	17,200 [5.0]	3.72	10,600 [3.1]	2.44	9.00
	17AHL18HM (RCSL-H*2417A*)	18,300 [5.4]	13,500 [4.0]	4,800 [1.4]	11.15	13.00	72	600 [283]	17,500 [5.1]	3.54	10,900 [3.2]	2.34	8.50
	UHKL-HM2417 (RCSL-H*2417A*)	18,900 [5.5]	13,950 [4.1]	4,950 [1.5]	12.15	14.00	72	650 [307]	17,200 [5.0]	3.72	10,600 [3.1]	2.44	8.90
UHLL-HM2417 (RCSL-H*2417A*)	18,600 [5.4]	13,750 [4.0]	4,850 [1.4]	12.00	14.00	72	600 [283]	17,200 [5.0]	3.72	10,600 [3.1]	2.44	9.00	
024JAZ	UHSL-HM2417 (RCSL-H*2417A*) ①	23,400 [6.9]	17,350 [5.1]	6,050 [1.8]	11.00	13.00	72	825 [389]	22,800 [6.7]	3.56	14,100 [4.1]	2.36	8.50
	RCFL-H*2414A*+RXMD-C04	23,200 [6.8]	17,150 [5.0]	6,050 [1.8]	10.60	13.00	72	825 [389]	23,000 [6.7]	3.46	14,300 [4.2]	2.30	8.15
	RCFL-H*2417A* (UGFD-06?MCK?)	23,400 [6.9]	17,400 [5.1]	6,000 [1.8]	11.30	13.50	72	800 [378]	22,000 [6.4]	3.92	13,300 [3.9]	2.56	9.20
	RCFL-H*2417A* (UGFD-07?MCK?)	23,600 [6.9]	17,450 [5.1]	6,150 [1.8]	11.40	13.50	72	800 [378]	22,000 [6.4]	3.92	13,300 [3.9]	2.56	9.20
	RCFL-H*2417A* (UGGD-06?MCK?)	23,600 [6.9]	17,500 [5.1]	6,100 [1.8]	11.60	14.00	72	800 [378]	22,000 [6.4]	3.92	13,300 [3.9]	2.56	9.20
	RCFL-H*2417A* (UGGD-07?MCK?)	23,600 [6.9]	17,450 [5.1]	6,150 [1.8]	11.50	14.00	72	800 [378]	22,000 [6.4]	3.92	13,300 [3.9]	2.56	9.20
	RCFL-H*2417A* (UGJD-06?MCK?)	23,600 [6.9]	17,500 [5.1]	6,100 [1.8]	11.60	14.00	72	800 [378]	22,000 [6.4]	3.92	13,300 [3.9]	2.56	9.20
	RCFL-H*2417A* (UGJD-07?MCK?)	23,600 [6.9]	17,450 [5.1]	6,150 [1.8]	11.50	14.00	72	800 [378]	22,000 [6.4]	3.92	13,300 [3.9]	2.56	9.20
	RCFL-H*2417A* (UGLR-07?AMK?)	23,600 [6.9]	17,550 [5.1]	6,050 [1.8]	11.75	14.00	72	800 [378]	22,000 [6.4]	3.92	13,300 [3.9]	2.56	9.20
	RCFL-H*2417A* (UGPR-05?BMK?)	23,200 [6.8]	17,250 [5.1]	5,950 [1.7]	11.30	13.50	72	775 [366]	22,600 [6.6]	3.64	13,800 [4.0]	2.40	8.45
	RCFL-H*2417A* (UGPR-07?AMK?)	23,600 [6.9]	17,500 [5.1]	6,100 [1.8]	11.65	14.00	72	800 [378]	22,600 [6.6]	3.64	13,800 [4.0]	2.40	8.45
	RCFL-H*2417A*+RXMD-C04	23,200 [6.8]	17,150 [5.0]	6,050 [1.8]	10.60	13.00	72	825 [389]	23,000 [6.7]	3.46	14,300 [4.2]	2.30	8.15
	17AHL24HM (RCSL-H*2417A*)	23,600 [6.9]	17,450 [5.1]	6,150 [1.8]	12.00	14.00	72	775 [366]	22,400 [6.6]	3.76	13,600 [4.0]	2.46	8.90

① Highest sales volume tested combination required by DOE test procedures.

[] Designates Metric Conversions

Performance Data ARI Standard Conditions—UPNL-

Note: Only these combinations of indoor/outdoor units are approved and any other combinations should not be used.

Model Numbers		ARI Cooling Performance							ARI Heating Performance (70°F [21°C] Indoor)				DOE Region IV HSPF
		80°F [26.5°C] DB/67°F [19.5°C] WB Indoor Air 95°F [35°C] DB Outdoor Air							Outdoor Air 47°F [8.5°C] DB/ 43°F [6°C] WB DOE High Temp.		Outdoor Air 17°F [-8.5°C] DB/ 15°F [-9.5°C] WB DOE Low Temp.		
Outdoor Unit UPNL-	Indoor Coil and/or Air Handler	Total Capacity BTU/H [kW]	Net Sens. BTU/H [kW]	Net Latent BTU/H [kW]	EER	SEER	Snd. Rate dB	Indoor CFM [L/s]	BTU/H [kW]	COP	BTU/H [kW]	COP	
Revised 4/21/2008													
024JAZ	17AHS24HM (RCSL-H*2417A*)	23,400 [6.9]	17,350 [5.1]	6,050 [1.8]	11.00	13.00	72	825 [389]	22,800 [6.7]	3.56	14,100 [4.1]	2.36	8.50
	UHKL-HM2417 (RCSL-H*2417A*)	23,600 [6.9]	17,500 [5.1]	6,100 [1.8]	11.60	14.00	72	850 [401]	22,000 [6.4]	3.92	13,300 [3.9]	2.56	9.20
	UHLL-HM2417 (RCSL-H*2417A*)	23,600 [6.9]	17,450 [5.1]	6,150 [1.8]	12.00	14.00	72	775 [366]	22,400 [6.6]	3.76	13,600 [4.0]	2.46	8.90
030JAZ	UHSL-HM3017 (RCSL-H*3617A*) ①	29,200 [8.6]	21,800 [6.4]	7,400 [2.2]	11.65	13.00	73	1,025 [484]	32,200 [9.4]	3.62	20,400 [6.0]	2.40	8.50
	RCFL-H*3617A*	29,000 [8.5]	21,600 [6.3]	7,400 [2.2]	11.50	13.00	73	1,025 [484]	32,400 [9.5]	3.60	20,400 [6.0]	2.40	8.40
	RCFL-H*3617A* (UGFD-07?MCK?)	29,400 [8.6]	21,950 [6.4]	7,450 [2.2]	12.05	14.00	73	1,000 [472]	31,000 [9.1]	4.00	19,200 [5.6]	2.66	9.25
	RCFL-H*3617A* (UGGD-06?MCK?)	29,400 [8.6]	21,950 [6.4]	7,450 [2.2]	12.05	14.00	73	1,000 [472]	31,000 [9.1]	4.00	19,200 [5.6]	2.66	9.25
	RCFL-H*3617A* (UGGD-07?MCK?)	29,400 [8.6]	21,900 [6.4]	7,500 [2.2]	11.95	14.00	73	1,025 [484]	31,000 [9.1]	4.00	19,200 [5.6]	2.66	9.25
	RCFL-H*3617A* (UGJD-06?MCK?)	29,400 [8.6]	21,950 [6.4]	7,450 [2.2]	12.05	14.00	73	1,000 [472]	31,000 [9.1]	4.00	19,200 [5.6]	2.66	9.25
	RCFL-H*3617A* (UGJD-07?MCK?)	29,400 [8.6]	21,900 [6.4]	7,500 [2.2]	11.95	14.00	73	1,025 [484]	31,000 [9.1]	4.00	19,200 [5.6]	2.66	9.25
	RCFL-H*3617A* (UGLR-07?AMK?)	29,600 [8.7]	22,050 [6.5]	7,550 [2.2]	12.30	14.00	73	1,025 [484]	31,000 [9.1]	4.00	19,200 [5.6]	2.66	9.25
	RCFL-H*3617A* (UGPR-05?BMK?)	29,400 [8.6]	21,900 [6.4]	7,500 [2.2]	11.95	14.00	73	1,000 [472]	31,000 [9.1]	4.00	19,200 [5.6]	2.66	9.25
	RCFL-H*3617A* (UGPR-07?AMK?)	29,600 [8.7]	22,050 [6.5]	7,550 [2.2]	12.25	14.00	73	1,000 [472]	31,000 [9.1]	4.00	19,200 [5.6]	2.66	9.25
	RCFL-H*3621A*	29,000 [8.5]	21,600 [6.3]	7,400 [2.2]	11.50	13.00	73	1,025 [484]	32,400 [9.5]	3.58	20,400 [6.0]	2.40	8.40
	RCFL-H*3621A* (UGFD-07?MCK?)	29,400 [8.6]	21,950 [6.4]	7,450 [2.2]	12.05	14.00	73	1,000 [472]	31,000 [9.1]	4.00	19,200 [5.6]	2.66	9.25
	RCFL-H*3621A* (UGGD-06?MCK?)	29,400 [8.6]	21,950 [6.4]	7,450 [2.2]	12.05	14.00	73	1,000 [472]	31,000 [9.1]	4.00	19,200 [5.6]	2.66	9.25
	RCFL-H*3621A* (UGGD-07?MCK?)	29,400 [8.6]	21,900 [6.4]	7,500 [2.2]	11.95	14.00	73	1,025 [484]	31,000 [9.1]	4.00	19,200 [5.6]	2.66	9.25
	RCFL-H*3621A* (UGJD-06?MCK?)	29,400 [8.6]	21,950 [6.4]	7,450 [2.2]	12.05	14.00	73	1,000 [472]	31,000 [9.1]	4.00	19,200 [5.6]	2.66	9.25
	RCFL-H*3621A* (UGJD-07?MCK?)	29,400 [8.6]	21,900 [6.4]	7,500 [2.2]	11.95	14.00	73	1,025 [484]	31,000 [9.1]	4.00	19,200 [5.6]	2.66	9.25
	RCFL-H*3621A* (UGLR-07?AMK?)	29,600 [8.7]	22,050 [6.5]	7,550 [2.2]	12.30	14.50	73	1,025 [484]	31,000 [9.1]	4.00	19,200 [5.6]	2.66	10.30
	RCFL-H*3621A* (UGLR-07?BRQ?)	29,800 [8.7]	22,250 [6.5]	7,550 [2.2]	12.65	15.00	73	1,000 [472]	31,600 [9.3]	3.80	19,800 [5.8]	2.54	9.25
	RCFL-H*3621A* (UGPR-05?BMK?)	29,400 [8.6]	21,900 [6.4]	7,500 [2.2]	11.95	14.00	73	1,000 [472]	31,000 [9.1]	4.00	19,200 [5.6]	2.66	9.25
	RCFL-H*3621A* (UGPR-07?AMK?)	29,600 [8.7]	22,050 [6.5]	7,550 [2.2]	12.25	14.00	73	1,000 [472]	31,000 [9.1]	4.00	19,200 [5.6]	2.66	9.25
RCFL-H*3621A* (UGPR-07?BRQ?)	29,800 [8.7]	22,200 [6.5]	7,600 [2.2]	12.65	15.00	73	1,000 [472]	31,000 [9.1]	4.00	19,200 [5.6]	2.66	9.25	
17AHL36HM (RCSL-H*3617A*)	29,800 [8.7]	22,200 [6.5]	7,600 [2.2]	12.75	15.00	73	1,000 [472]	31,600 [9.3]	3.80	19,800 [5.8]	2.54	9.25	
17AHS30HM (RCSL-H*3617A*)	29,200 [8.6]	21,800 [6.4]	7,400 [2.2]	11.65	13.00	73	1,025 [484]	32,200 [9.4]	3.62	20,400 [6.0]	2.40	8.50	
RCSL-H*3617A* (UGFD-07?MCK?)	29,400 [8.6]	21,950 [6.4]	7,450 [2.2]	12.05	14.00	73	1,000 [472]	32,000 [9.4]	3.70	20,200 [5.9]	2.46	9.25	
RCSL-H*3617A* (UGGD-06?MCK?)	29,400 [8.6]	21,950 [6.4]	7,450 [2.2]	12.05	14.00	73	1,000 [472]	32,000 [9.4]	3.70	20,200 [5.9]	2.48	9.25	
RCSL-H*3617A* (UGGD-07?MCK?)	29,400 [8.6]	21,900 [6.4]	7,500 [2.2]	11.95	14.00	73	1,025 [484]	32,000 [9.4]	3.70	20,200 [5.9]	2.46	9.25	

① Highest sales volume tested combination required by DOE test procedures.

[] Designates Metric Conversions

Performance Data ARI Standard Conditions—UPNL-

Note: Only these combinations of indoor/outdoor units are approved and any other combinations should not be used.

Model Numbers		ARI Cooling Performance							ARI Heating Performance (70°F [21°C] Indoor)				
		80°F [26.5°C] DB/67°F [19.5°C] WB Indoor Air 95°F [35°C] DB Outdoor Air							Outdoor Air 47°F [8.5°C] DB/ 43°F [6°C] WB DOE High Temp.		Outdoor Air 17°F [-8.5°C] DB/ 15°F [-9.5°C] WB DOE Low Temp.		DOE Region IV HSPF
Outdoor Unit UPNL-	Indoor Coil and/or Air Handler	Total Capacity BTU/H [kW]	Net Sens. BTU/H [kW]	Net Latent BTU/H [kW]	EER	SEER	Snd. Rate dB	Indoor CFM [L/s]	BTU/H [kW]	COP	BTU/H [kW]	COP	
Revised 4/21/2008													
030JAZ	RCSL-H*3617A* (UGJD-06?MCK?)	29,400 [8.6]	21,950 [6.4]	7,450 [2.2]	12.05	14.00	73	1,000 [472]	32,000 [9.4]	3.70	20,200 [5.9]	2.48	9.25
	RCSL-H*3617A* (UGJD-07?MCK?)	29,400 [8.6]	21,900 [6.4]	7,500 [2.2]	11.95	14.00	73	1,025 [484]	32,000 [9.4]	3.70	20,200 [5.9]	2.46	9.25
	RCSL-H*3617A* (UGPR-05?BMK?)	29,400 [8.6]	21,900 [6.4]	7,500 [2.2]	11.95	14.00	73	1,000 [472]	32,000 [9.4]	3.68	20,200 [5.9]	2.46	9.25
	UHKL-HM3617 (RCSL-H*3617A*)	29,600 [8.7]	22,150 [6.5]	7,450 [2.2]	12.60	14.00	73	1,025 [484]	31,600 [9.3]	3.80	19,800 [5.8]	2.52	9.25
	UHLL-HM3617 (RCSL-H*3617A*)	29,800 [8.7]	22,200 [6.5]	7,600 [2.2]	12.75	15.00	73	1,000 [472]	31,600 [9.3]	3.80	19,800 [5.8]	2.54	9.25
	RCSL-H*3621A*	29,000 [8.5]	21,600 [6.3]	7,400 [2.2]	11.50	13.00	73	1,025 [484]	32,400 [9.5]	3.58	20,400 [6.0]	2.40	9.25
	RCSL-H*3621A* (UGFD-07?MCK?)	29,400 [8.6]	21,950 [6.4]	7,450 [2.2]	12.05	14.00	73	1,000 [472]	32,000 [9.4]	3.70	20,200 [5.9]	2.46	9.25
	RCSL-H*3621A* (UGGD-06?MCK?)	29,400 [8.6]	21,950 [6.4]	7,450 [2.2]	12.05	14.00	73	1,000 [472]	32,000 [9.4]	3.70	20,200 [5.9]	2.48	9.25
	RCSL-H*3621A* (UGGD-07?MCK?)	29,400 [8.6]	21,900 [6.4]	7,500 [2.2]	11.95	14.00	73	1,025 [484]	32,000 [9.4]	3.70	20,200 [5.9]	2.46	9.25
	RCSL-H*3621A* (UGJD-06?MCK?)	29,400 [8.6]	21,950 [6.4]	7,450 [2.2]	12.05	14.00	73	1,000 [472]	32,000 [9.4]	3.70	20,200 [5.9]	2.48	9.25
	RCSL-H*3621A* (UGJD-07?MCK?)	29,400 [8.6]	21,900 [6.4]	7,500 [2.2]	11.95	14.00	73	1,025 [484]	32,000 [9.4]	3.70	20,200 [5.9]	2.46	9.25
	RCSL-H*3621A* (UGLR-07?AMK?)	29,600 [8.7]	22,050 [6.5]	7,550 [2.2]	12.30	14.00	73	1,025 [484]	31,800 [9.3]	3.74	20,000 [5.9]	2.50	9.25
	RCSL-H*3621A* (UGPR-05?BMK?)	29,400 [8.6]	21,900 [6.4]	7,500 [2.2]	11.95	14.00	73	1,000 [472]	32,000 [9.4]	3.68	20,200 [5.9]	2.46	9.25
	RCSL-H*3621A* (UGPR-07?AMK?)	29,600 [8.7]	22,050 [6.5]	7,550 [2.2]	12.25	14.00	73	1,000 [472]	31,800 [9.3]	3.72	20,000 [5.9]	2.50	9.25
RCSL-H*3621A* (UGPR-07?BRQ?)	29,800 [8.7]	22,200 [6.5]	7,600 [2.2]	12.65	15.00	73	1,000 [472]	31,600 [9.3]	3.80	19,800 [5.8]	2.54	9.25	
036CAZ	RCFL-H*3617A*	37,600 [11.0]	26,550 [7.8]	11,050 [3.2]	11.20	13.00	76	1,100 [519]	39,000 [11.4]	3.50	26,000 [7.6]	2.64	8.40
	RCFL-H*3621A*	38,000 [11.1]	26,850 [7.9]	11,150 [3.3]	11.25	13.00	76	1,200 [566]	39,000 [11.4]	3.52	26,000 [7.6]	2.68	8.45
	RCFL-H*3621A* (UGGD-09?ZCM?)	38,500 [11.3]	27,250 [8.0]	11,250 [3.3]	11.85	13.50	76	1,175 [554]	38,500 [11.3]	3.88	25,600 [7.5]	2.96	9.15
	RCFL-H*3621A* (UGGD-10?ZCM?)	38,500 [11.3]	27,250 [8.0]	11,250 [3.3]	11.85	13.50	76	1,175 [554]	38,500 [11.3]	3.88	25,600 [7.5]	2.96	9.15
	RCFL-H*3621A* (UGJD-09?ZCM?)	38,500 [11.3]	27,250 [8.0]	11,250 [3.3]	11.85	13.50	76	1,175 [554]	38,500 [11.3]	3.88	25,600 [7.5]	2.96	9.15
	RCFL-H*3621A* (UGJD-10?ZCM?)	38,500 [11.3]	27,250 [8.0]	11,250 [3.3]	11.85	13.50	76	1,175 [554]	38,500 [11.3]	3.88	25,600 [7.5]	2.96	9.15
	RCFL-H*3621A* (UGLR-07?BRQ?)	38,500 [11.3]	27,500 [8.1]	11,000 [3.2]	12.00	14.00	76	1,225 [578]	38,500 [11.3]	3.64	25,600 [7.5]	2.78	8.70
	RCFL-H*3621A* (UGLR-10?BRM?)	38,500 [11.3]	27,300 [8.0]	11,200 [3.3]	12.00	14.00	76	1,200 [566]	38,500 [11.3]	3.88	25,600 [7.5]	2.96	9.15
	RCFL-H*3621A* (UGPR-07?BRQ?)	38,500 [11.3]	27,300 [8.0]	11,200 [3.3]	12.00	14.00	76	1,200 [566]	38,500 [11.3]	3.64	25,600 [7.5]	2.76	8.70
	RCFL-H*3621A* (UGPR-10?BRM?)	38,500 [11.3]	27,200 [8.0]	11,300 [3.3]	11.75	13.50	76	1,225 [578]	38,500 [11.3]	3.64	25,800 [7.6]	2.76	8.70
	17AHL36HM (RCSL-H*3617A*)	38,500 [11.3]	27,350 [8.0]	11,150 [3.3]	12.05	14.00	76	1,200 [566]	39,500 [11.6]	3.88	25,600 [7.5]	2.96	9.15
	17AHS36HM (RCSL-H*3617A*)	38,000 [11.1]	26,850 [7.9]	11,150 [3.3]	11.45	13.00	76	1,200 [566]	39,500 [11.6]	3.54	26,400 [7.7]	2.60	8.50
	UHKL-HM3617 (RCSL-H*3617A*)	38,500 [11.3]	27,250 [8.0]	11,250 [3.3]	11.85	13.50	76	1,225 [578]	38,500 [11.3]	3.88	25,800 [7.6]	2.96	9.15
UHLL-HM3617 (RCSL-H*3617A*)	38,500 [11.3]	27,350 [8.0]	11,150 [3.3]	12.05	14.00	76	1,200 [566]	38,500 [11.3]	3.88	25,600 [7.5]	2.96	9.15	

① Highest sales volume tested combination required by DOE test procedures.

[] Designates Metric Conversions

Performance Data ARI Standard Conditions—UPNL-

Note: Only these combinations of indoor/outdoor units are approved and any other combinations should not be used.

Model Numbers		ARI Cooling Performance							ARI Heating Performance (70°F [21°C] Indoor)				DOE Region IV HSPF
		80°F [26.5°C] DB/67°F [19.5°C] WB Indoor Air 95°F [35°C] DB Outdoor Air							Outdoor Air 47°F [8.5°C] DB/ 43°F [6°C] WB DOE High Temp.		Outdoor Air 17°F [-8.5°C] DB/ 15°F [-9.5°C] WB DOE Low Temp.		
Outdoor Unit UPNL-	Indoor Coil and/or Air Handler	Total Capacity BTU/H [kW]	Net Sens. BTU/H [kW]	Net Latent BTU/H [kW]	EER	SEER	Snd. Rate dB	Indoor CFM [L/s]	BTU/H [kW]	COP	BTU/H [kW]	COP	
Revised 4/21/2008													
036CAZ	UHSL-HM3617 (RCSL-H*3617A*)	38,000 [11.1]	26,850 [7.9]	11,150 [3.3]	11.45	13.00	76	1,200 [566]	39,500 [11.6]	3.54	26,400 [7.7]	2.60	8.50
	UHSL-HM3621 (RCSL-H*3621A*)	38,000 [11.1]	26,850 [7.9]	11,150 [3.3]	11.45	13.00	76	1,200 [566]	39,500 [11.6]	3.54	26,400 [7.7]	2.60	8.50
036DAZ	RCFL-H*3617A*	37,600 [11.0]	26,550 [7.8]	11,050 [3.2]	11.20	13.00	76	1,100 [519]	39,000 [11.4]	3.50	26,000 [7.6]	2.64	8.40
	RCFL-H*3621A*	38,000 [11.1]	26,850 [7.9]	11,150 [3.3]	11.25	13.00	76	1,200 [566]	39,000 [11.4]	3.52	26,000 [7.6]	2.68	8.45
	RCFL-H*3621A* (UGGD-09?ZCM?)	38,500 [11.3]	27,250 [8.0]	11,250 [3.3]	11.85	13.50	76	1,175 [554]	38,500 [11.3]	3.88	25,600 [7.5]	2.96	9.15
	RCFL-H*3621A* (UGGD-10?ZCM?)	38,500 [11.3]	27,250 [8.0]	11,250 [3.3]	11.85	13.50	76	1,175 [554]	38,500 [11.3]	3.88	25,600 [7.5]	2.96	9.15
	RCFL-H*3621A* (UGJD-09?ZCM?)	38,500 [11.3]	27,250 [8.0]	11,250 [3.3]	11.85	13.50	76	1,175 [554]	38,500 [11.3]	3.88	25,600 [7.5]	2.96	9.15
	RCFL-H*3621A* (UGJD-10?ZCM?)	38,500 [11.3]	27,250 [8.0]	11,250 [3.3]	11.85	13.50	76	1,175 [554]	38,500 [11.3]	3.88	25,600 [7.5]	2.96	9.15
	RCFL-H*3621A* (UGLR-07?BRQ?)	38,500 [11.3]	27,500 [8.1]	11,000 [3.2]	12.00	14.00	76	1,225 [578]	38,500 [11.3]	3.64	25,600 [7.5]	2.78	8.70
	RCFL-H*3621A* (UGLR-10?BRM?)	38,500 [11.3]	27,300 [8.0]	11,200 [3.3]	12.00	14.00	76	1,200 [566]	38,500 [11.3]	3.88	25,600 [7.5]	2.96	9.15
	RCFL-H*3621A* (UGPR-07?BRQ?)	38,500 [11.3]	27,300 [8.0]	11,200 [3.3]	12.00	14.00	76	1,200 [566]	38,500 [11.3]	3.64	25,600 [7.5]	2.76	8.70
	RCFL-H*3621A* (UGPR-10?BRM?)	38,500 [11.3]	27,200 [8.0]	11,300 [3.3]	11.75	13.50	76	1,225 [578]	38,500 [11.3]	3.64	25,800 [7.6]	2.76	8.70
	17AHL36HM (RCSL-H*3617A*)	38,500 [11.3]	27,350 [8.0]	11,150 [3.3]	12.05	14.00	76	1,200 [566]	39,500 [11.6]	3.88	25,600 [7.5]	2.96	9.15
	17AHS36HM (RCSL-H*3617A*)	38,000 [11.1]	26,850 [7.9]	11,150 [3.3]	11.45	13.00	76	1,200 [566]	39,500 [11.6]	3.54	26,400 [7.7]	2.60	8.50
	UHKL-HM3617 (RCSL-H*3617A*)	38,500 [11.3]	27,250 [8.0]	11,250 [3.3]	11.85	13.50	76	1,225 [578]	38,500 [11.3]	3.88	25,800 [7.6]	2.96	9.15
	UHLL-HM3617 (RCSL-H*3617A*)	38,500 [11.3]	27,350 [8.0]	11,150 [3.3]	12.05	14.00	76	1,200 [566]	38,500 [11.3]	3.88	25,600 [7.5]	2.96	9.15
	UHSL-HM3617 (RCSL-H*3617A*)	38,000 [11.1]	26,850 [7.9]	11,150 [3.3]	11.45	13.00	76	1,200 [566]	39,500 [11.6]	3.54	26,400 [7.7]	2.60	8.50
	UHSL-HM3621 (RCSL-H*3621A*)	38,000 [11.1]	26,850 [7.9]	11,150 [3.3]	11.45	13.00	76	1,200 [566]	39,500 [11.6]	3.54	26,400 [7.7]	2.60	8.50
036JAZ	UHSL-HM3617 (RCSL-H*3617A*) ①	38,000 [11.1]	26,850 [7.9]	11,150 [3.3]	11.45	13.00	76	1,200 [566]	39,500 [11.6]	3.54	26,400 [7.7]	2.60	8.50
	RCFL-H*3617A*	37,600 [11.0]	26,550 [7.8]	11,050 [3.2]	11.20	13.00	76	1,100 [519]	39,000 [11.4]	3.50	26,000 [7.6]	2.64	8.40
	RCFL-H*3621A*	38,000 [11.1]	26,850 [7.9]	11,150 [3.3]	11.25	13.00	76	1,200 [566]	39,000 [11.4]	3.52	26,000 [7.6]	2.68	8.45
	RCFL-H*3621A* (UGGD-09?ZCM?)	38,500 [11.3]	27,250 [8.0]	11,250 [3.3]	11.85	13.50	76	1,175 [554]	38,500 [11.3]	3.88	25,600 [7.5]	2.96	9.15
	RCFL-H*3621A* (UGGD-10?ZCM?)	38,500 [11.3]	27,250 [8.0]	11,250 [3.3]	11.85	13.50	76	1,175 [554]	38,500 [11.3]	3.88	25,600 [7.5]	2.96	9.15
	RCFL-H*3621A* (UGJD-09?ZCM?)	38,500 [11.3]	27,250 [8.0]	11,250 [3.3]	11.85	13.50	76	1,175 [554]	38,500 [11.3]	3.88	25,600 [7.5]	2.96	9.15
	RCFL-H*3621A* (UGJD-10?ZCM?)	38,500 [11.3]	27,250 [8.0]	11,250 [3.3]	11.85	13.50	76	1,175 [554]	38,500 [11.3]	3.88	25,600 [7.5]	2.96	9.15
	RCFL-H*3621A* (UGLR-07?BRQ?)	38,500 [11.3]	27,500 [8.1]	11,000 [3.2]	12.00	14.00	76	1,225 [578]	38,500 [11.3]	3.64	25,600 [7.5]	2.78	8.70
	RCFL-H*3621A* (UGLR-10?BRM?)	38,500 [11.3]	27,300 [8.0]	11,200 [3.3]	12.00	14.00	76	1,200 [566]	38,500 [11.3]	3.88	25,600 [7.5]	2.96	9.15
	RCFL-H*3621A* (UGPR-07?BRQ?)	38,500 [11.3]	27,300 [8.0]	11,200 [3.3]	12.00	14.00	76	1,200 [566]	38,500 [11.3]	3.64	25,600 [7.5]	2.76	8.70
	RCFL-H*3621A* (UGPR-10?BRM?)	38,500 [11.3]	27,200 [8.0]	11,300 [3.3]	11.75	13.50	76	1,225 [578]	38,500 [11.3]	3.64	25,800 [7.6]	2.76	8.70

① Highest sales volume tested combination required by DOE test procedures.

[] Designates Metric Conversions

Performance Data ARI Standard Conditions—UPNL-

Note: Only these combinations of indoor/outdoor units are approved and any other combinations should not be used.

Model Numbers		ARI Cooling Performance							ARI Heating Performance (70°F [21°C] Indoor)				
		80°F [26.5°C] DB/67°F [19.5°C] WB Indoor Air 95°F [35°C] DB Outdoor Air							Outdoor Air 47°F [8.5°C] DB/ 43°F [6°C] WB DOE High Temp.		Outdoor Air 17°F [-8.5°C] DB/ 15°F [-9.5°C] WB DOE Low Temp.		DOE Region IV HSPF
Outdoor Unit UPNL-	Indoor Coil and/or Air Handler	Total Capacity BTU/H [kW]	Net Sens. BTU/H [kW]	Net Latent BTU/H [kW]	EER	SEER	Snd. Rate dB	Indoor CFM [L/s]	BTU/H [kW]	COP	BTU/H [kW]	COP	
Revised 4/21/2008													
036JAZ	17AHL36HM (RCSL-H*3617A*)	38,500 [11.3]	27,350 [8.0]	11,150 [3.3]	12.05	14.00	76	1,200 [566]	39,500 [11.6]	3.88	25,600 [7.5]	2.96	9.15
	17AHS36HM (RCSL-H*3617A*)	38,000 [11.1]	26,850 [7.9]	11,150 [3.3]	11.45	13.00	76	1,200 [566]	39,500 [11.6]	3.54	26,400 [7.7]	2.60	8.50
	UHKL-HM3617 (RCSL-H*3617A*)	38,500 [11.3]	27,250 [8.0]	11,250 [3.3]	11.85	13.50	76	1,225 [578]	38,500 [11.3]	3.88	25,800 [7.6]	2.96	9.15
	UHLL-HM3617 (RCSL-H*3617A*)	38,500 [11.3]	27,350 [8.0]	11,150 [3.3]	12.05	14.00	76	1,200 [566]	38,500 [11.3]	3.88	25,600 [7.5]	2.96	9.15
	UHSL-HM3621 (RCSL-H*3621A*)	38,000 [11.1]	26,850 [7.9]	11,150 [3.3]	11.45	13.00	76	1,200 [566]	39,500 [11.6]	3.54	26,400 [7.7]	2.60	8.50
042CAZ	RCFL-H*4821A*	42,500 [12.5]	30,300 [8.9]	12,200 [3.6]	11.50	13.00	76	1,400 [661]	42,500 [12.5]	3.64	28,600 [8.4]	2.64	8.40
	RCFL-H*4821A* (UGLR-07?BRQ?)	43,000 [12.6]	30,750 [9.0]	12,250 [3.6]	11.95	14.00	76	1,425 [672]	42,000 [12.3]	3.74	28,200 [8.3]	2.72	9.85
	RCFL-H*4821A* (UGLR-10?BRM?)	43,500 [12.7]	31,000 [9.1]	12,500 [3.7]	12.10	14.00	76	1,375 [649]	42,000 [12.3]	3.72	28,200 [8.3]	2.70	8.60
	RCFL-H*4821A* (UGPR-07?BRQ?)	43,000 [12.6]	30,950 [9.1]	12,050 [3.5]	12.05	14.00	76	1,400 [661]	42,500 [12.5]	3.68	28,400 [8.3]	2.68	8.50
	RCFL-H*4821A* (UGPR-10?BRM?)	43,000 [12.6]	30,800 [9.0]	12,200 [3.6]	11.80	14.00	76	1,425 [672]	42,500 [12.5]	3.68	28,400 [8.3]	2.68	8.50
	RCFL-H*4824A*	42,500 [12.5]	30,300 [8.9]	12,200 [3.6]	11.50	13.00	76	1,400 [661]	42,500 [12.5]	3.64	28,600 [8.4]	2.64	8.40
	RCFL-H*4824A* (UGGD-12?RCM?)	43,500 [12.7]	31,050 [9.1]	12,450 [3.6]	11.95	14.00	76	1,450 [684]	42,000 [12.3]	3.74	28,200 [8.3]	2.72	8.65
	RCFL-H*4824A* (UGJD-12?RCM?)	43,500 [12.7]	31,050 [9.1]	12,450 [3.6]	11.95	14.00	76	1,450 [684]	42,000 [12.3]	3.72	28,200 [8.3]	2.70	8.65
	RCFL-H*4824A* (UGLR-07?BRQ?)	43,000 [12.6]	30,750 [9.0]	12,250 [3.6]	11.95	14.00	76	1,425 [672]	42,000 [12.3]	3.74	28,200 [8.3]	2.72	8.50
	RCFL-H*4824A* (UGLR-10?BRM?)	43,500 [12.7]	31,000 [9.1]	12,500 [3.7]	12.10	14.00	76	1,375 [649]	42,000 [12.3]	3.72	28,200 [8.3]	2.70	8.65
	RCFL-H*4824A* (UGLR-12?ARM?)	43,000 [12.6]	30,950 [9.1]	12,050 [3.5]	12.05	14.00	76	1,425 [672]	42,000 [12.3]	3.72	28,200 [8.3]	2.70	8.65
	RCFL-H*4824A* (UGPR-07?BRQ?)	43,000 [12.6]	30,950 [9.1]	12,050 [3.5]	12.05	14.00	76	1,400 [661]	42,500 [12.5]	3.68	28,400 [8.3]	2.68	8.50
	RCFL-H*4824A* (UGPR-10?BRM?)	43,000 [12.6]	30,800 [9.0]	12,200 [3.6]	11.80	14.00	76	1,425 [672]	42,500 [12.5]	3.68	28,400 [8.3]	2.68	8.50
	RCFL-H*4824A* (UGPR-12?ARM?)	43,000 [12.6]	30,950 [9.1]	12,050 [3.5]	12.05	14.00	76	1,400 [661]	42,500 [12.5]	3.68	28,400 [8.3]	2.68	8.50
	21AHL48HM (RCSL-H*4821A*)	43,500 [12.7]	31,100 [9.1]	12,400 [3.6]	12.35	14.00	76	1,400 [661]	41,000 [12.0]	4.08	27,000 [7.9]	2.96	9.35
	21AHS42HM (RCSL-H*4821A*)	43,000 [12.6]	30,800 [9.0]	12,200 [3.6]	11.60	13.00	76	1,400 [661]	42,500 [12.5]	3.64	28,600 [8.4]	2.66	8.50
	UHKL-HM4821 (RCSL-H*4821A*)	43,500 [12.7]	31,050 [9.1]	12,450 [3.6]	12.25	14.00	76	1,400 [661]	41,000 [12.0]	4.10	27,000 [7.9]	2.96	9.35
	UHLL-HM4821 (RCSL-H*4821A*)	43,500 [12.7]	31,100 [9.1]	12,400 [3.6]	12.35	14.00	76	1,400 [661]	41,000 [12.0]	4.10	27,000 [7.9]	2.96	9.35
UHSL-HM4221 (RCSL-H*4821A*)	43,000 [12.6]	30,800 [9.0]	12,200 [3.6]	11.60	13.00	76	1,400 [661]	42,500 [12.5]	3.66	28,600 [8.4]	2.66	8.50	
042DAZ	RCFL-H*4821A*	42,500 [12.5]	30,300 [8.9]	12,200 [3.6]	11.50	13.00	76	1,400 [661]	42,500 [12.5]	3.64	28,600 [8.4]	2.64	8.40
	RCFL-H*4821A* (UGLR-07?BRQ?)	43,000 [12.6]	30,750 [9.0]	12,250 [3.6]	11.95	14.00	76	1,425 [672]	42,000 [12.3]	3.74	28,200 [8.3]	2.72	9.85
	RCFL-H*4821A* (UGLR-10?BRM?)	43,500 [12.7]	31,000 [9.1]	12,500 [3.7]	12.10	14.00	76	1,375 [649]	42,000 [12.3]	3.72	28,200 [8.3]	2.70	8.60
	RCFL-H*4821A* (UGPR-07?BRQ?)	43,000 [12.6]	30,950 [9.1]	12,050 [3.5]	12.05	14.00	76	1,400 [661]	42,500 [12.5]	3.68	28,400 [8.3]	2.68	8.50
	RCFL-H*4821A* (UGPR-10?BRM?)	43,000 [12.6]	30,800 [9.0]	12,200 [3.6]	11.80	14.00	76	1,425 [672]	42,500 [12.5]	3.68	28,400 [8.3]	2.68	8.50

① Highest sales volume tested combination required by DOE test procedures.

[] Designates Metric Conversions

Performance Data ARI Standard Conditions—UPNL-

Note: Only these combinations of indoor/outdoor units are approved and any other combinations should not be used.

Model Numbers		ARI Cooling Performance							ARI Heating Performance (70°F [21°C] Indoor)				
		80°F [26.5°C] DB/67°F [19.5°C] WB Indoor Air 95°F [35°C] DB Outdoor Air							Outdoor Air 47°F [8.5°C] DB/ 43°F [6°C] WB DOE High Temp.		Outdoor Air 17°F [-8.5°C] DB/ 15°F [-9.5°C] WB DOE Low Temp.		DOE Region IV HSPF
Outdoor Unit UPNL-	Indoor Coil and/or Air Handler	Total Capacity BTU/H [kW]	Net Sens. BTU/H [kW]	Net Latent BTU/H [kW]	EER	SEER	Snd. Rate dB	Indoor CFM [L/s]	BTU/H [kW]	COP	BTU/H [kW]	COP	
Revised 4/21/2008													
042DAZ	RCFL-H*4824A*	42,500 [12.5]	30,300 [8.9]	12,200 [3.6]	11.50	13.00	76	1,400 [661]	42,500 [12.5]	3.64	28,600 [8.4]	2.64	8.40
	RCFL-H*4824A* (UGGD-12?RCM?)	43,500 [12.7]	31,050 [9.1]	12,450 [3.6]	11.95	14.00	76	1,450 [684]	42,000 [12.3]	3.74	28,200 [8.3]	2.72	8.65
	RCFL-H*4824A* (UGJD-12?RCM?)	43,500 [12.7]	31,050 [9.1]	12,450 [3.6]	11.95	14.00	76	1,450 [684]	42,000 [12.3]	3.72	28,200 [8.3]	2.70	8.65
	RCFL-H*4824A* (UGLR-07?BRQ?)	43,000 [12.6]	30,750 [9.0]	12,250 [3.6]	11.95	14.00	76	1,425 [672]	42,000 [12.3]	3.74	28,200 [8.3]	2.72	8.50
	RCFL-H*4824A* (UGLR-10?BRM?)	43,500 [12.7]	31,000 [9.1]	12,500 [3.7]	12.10	14.00	76	1,375 [649]	42,000 [12.3]	3.72	28,200 [8.3]	2.70	8.65
	RCFL-H*4824A* (UGLR-12?ARM?)	43,000 [12.6]	30,950 [9.1]	12,050 [3.5]	12.05	14.00	76	1,425 [672]	42,000 [12.3]	3.72	28,200 [8.3]	2.70	8.65
	RCFL-H*4824A* (UGPR-07?BRQ?)	43,000 [12.6]	30,950 [9.1]	12,050 [3.5]	12.05	14.00	76	1,400 [661]	42,500 [12.5]	3.68	28,400 [8.3]	2.68	8.50
	RCFL-H*4824A* (UGPR-10?BRM?)	43,000 [12.6]	30,800 [9.0]	12,200 [3.6]	11.80	14.00	76	1,425 [672]	42,500 [12.5]	3.68	28,400 [8.3]	2.68	8.50
	RCFL-H*4824A* (UGPR-12?ARM?)	43,000 [12.6]	30,950 [9.1]	12,050 [3.5]	12.05	14.00	76	1,400 [661]	42,500 [12.5]	3.68	28,400 [8.3]	2.68	8.50
	21AHL48HM (RCSL-H*4821A*)	43,500 [12.7]	31,100 [9.1]	12,400 [3.6]	12.35	14.00	76	1,400 [661]	41,000 [12.0]	4.08	27,000 [7.9]	2.96	9.35
	21AHS42HM (RCSL-H*4821A*)	43,000 [12.6]	30,800 [9.0]	12,200 [3.6]	11.60	13.00	76	1,400 [661]	42,500 [12.5]	3.64	28,600 [8.4]	2.66	8.50
	UHKL-HM4821 (RCSL-H*4821A*)	43,500 [12.7]	31,050 [9.1]	12,450 [3.6]	12.25	14.00	76	1,400 [661]	41,000 [12.0]	4.10	27,000 [7.9]	2.96	9.35
	UHLL-HM4821 (RCSL-H*4821A*)	43,500 [12.7]	31,100 [9.1]	12,400 [3.6]	12.35	14.00	76	1,400 [661]	41,000 [12.0]	4.10	27,000 [7.9]	2.96	9.35
	UHSL-HM4221 (RCSL-H*4821A*)	43,000 [12.6]	30,800 [9.0]	12,200 [3.6]	11.60	13.00	76	1,400 [661]	42,500 [12.5]	3.66	28,600 [8.4]	2.66	8.50
042JAZ	UHSL-HM4221 (RCSL-H*4821A*) ①	43,000 [12.6]	30,800 [9.0]	12,200 [3.6]	11.60	13.00	76	1,400 [661]	42,500 [12.5]	3.66	28,600 [8.4]	2.66	8.50
	RCFL-H*4821A*	42,500 [12.5]	30,300 [8.9]	12,200 [3.6]	11.50	13.00	76	1,400 [661]	42,500 [12.5]	3.64	28,600 [8.4]	2.64	8.40
	RCFL-H*4821A* (UGLR-07?BRQ?)	43,000 [12.6]	30,750 [9.0]	12,250 [3.6]	11.95	14.00	76	1,425 [672]	42,000 [12.3]	3.74	28,200 [8.3]	2.72	9.85
	RCFL-H*4821A* (UGLR-10?BRM?)	43,500 [12.7]	31,000 [9.1]	12,500 [3.7]	12.10	14.00	76	1,375 [649]	42,000 [12.3]	3.72	28,200 [8.3]	2.70	8.60
	RCFL-H*4821A* (UGPR-07?BRQ?)	43,000 [12.6]	30,950 [9.1]	12,050 [3.5]	12.05	14.00	76	1,400 [661]	42,500 [12.5]	3.68	28,400 [8.3]	2.68	8.50
	RCFL-H*4821A* (UGPR-10?BRM?)	43,000 [12.6]	30,800 [9.0]	12,200 [3.6]	11.80	14.00	76	1,425 [672]	42,500 [12.5]	3.68	28,400 [8.3]	2.68	8.50
	RCFL-H*4824A*	42,500 [12.5]	30,300 [8.9]	12,200 [3.6]	11.50	13.00	76	1,400 [661]	42,500 [12.5]	3.64	28,600 [8.4]	2.64	8.40
	RCFL-H*4824A* (UGGD-12?RCM?)	43,500 [12.7]	31,050 [9.1]	12,450 [3.6]	11.95	14.00	76	1,450 [684]	42,000 [12.3]	3.74	28,200 [8.3]	2.72	8.65
	RCFL-H*4824A* (UGJD-12?RCM?)	43,500 [12.7]	31,050 [9.1]	12,450 [3.6]	11.95	14.00	76	1,450 [684]	42,000 [12.3]	3.72	28,200 [8.3]	2.70	8.65
	RCFL-H*4824A* (UGLR-07?BRQ?)	43,000 [12.6]	30,750 [9.0]	12,250 [3.6]	11.95	14.00	76	1,425 [672]	42,000 [12.3]	3.74	28,200 [8.3]	2.72	8.50
	RCFL-H*4824A* (UGLR-10?BRM?)	43,500 [12.7]	31,000 [9.1]	12,500 [3.7]	12.10	14.00	76	1,375 [649]	42,000 [12.3]	3.72	28,200 [8.3]	2.70	8.65
	RCFL-H*4824A* (UGLR-12?ARM?)	43,000 [12.6]	30,950 [9.1]	12,050 [3.5]	12.05	14.00	76	1,425 [672]	42,000 [12.3]	3.72	28,200 [8.3]	2.70	8.65
	RCFL-H*4824A* (UGPR-07?BRQ?)	43,000 [12.6]	30,950 [9.1]	12,050 [3.5]	12.05	14.00	76	1,400 [661]	42,500 [12.5]	3.68	28,400 [8.3]	2.68	8.50
	RCFL-H*4824A* (UGPR-10?BRM?)	43,000 [12.6]	30,800 [9.0]	12,200 [3.6]	11.80	14.00	76	1,425 [672]	42,500 [12.5]	3.68	28,400 [8.3]	2.68	8.50
RCFL-H*4824A* (UGPR-12?ARM?)	43,000 [12.6]	30,950 [9.1]	12,050 [3.5]	12.05	14.00	76	1,400 [661]	42,500 [12.5]	3.68	28,400 [8.3]	2.68	8.50	

① Highest sales volume tested combination required by DOE test procedures.

[] Designates Metric Conversions

Performance Data ARI Standard Conditions—UPNL-

Note: Only these combinations of indoor/outdoor units are approved and any other combinations should not be used.

Model Numbers		ARI Cooling Performance							ARI Heating Performance (70°F [21°C] Indoor)				
		80°F [26.5°C] DB/67°F [19.5°C] WB Indoor Air 95°F [35°C] DB Outdoor Air							Outdoor Air 47°F [8.5°C] DB/ 43°F [6°C] WB DOE High Temp.		Outdoor Air 17°F [-8.5°C] DB/ 15°F [-9.5°C] WB DOE Low Temp.		DOE Region IV HSPF
Outdoor Unit UPNL-	Indoor Coil and/or Air Handler	Total Capacity BTU/H [kW]	Net Sens. BTU/H [kW]	Net Latent BTU/H [kW]	EER	SEER	Snd. Rate dB	Indoor CFM [L/s]	BTU/H [kW]	COP	BTU/H [kW]	COP	
Revised 4/21/2008													
042JAZ	21AHL48HM (RCSL-H*4821A*)	43,500 [12.7]	31,100 [9.1]	12,400 [3.6]	12.35	14.00	76	1,400 [661]	41,000 [12.0]	4.08	27,000 [7.9]	2.96	9.35
	21AHL42HM (RCSL-H*4821A*)	43,000 [12.6]	30,800 [9.0]	12,200 [3.6]	11.60	13.00	76	1,400 [661]	42,500 [12.5]	3.64	28,600 [8.4]	2.66	8.50
	UHKL-HM4821 (RCSL-H*4821A*)	43,500 [12.7]	31,050 [9.1]	12,450 [3.6]	12.25	14.00	76	1,400 [661]	41,000 [12.0]	4.10	27,000 [7.9]	2.96	9.35
	UHLL-HM4821 (RCSL-H*4821A*)	43,500 [12.7]	31,100 [9.1]	12,400 [3.6]	12.35	14.00	76	1,400 [661]	41,000 [12.0]	4.10	27,000 [7.9]	2.96	9.35
048CAZ	RCFL-H*4821A*	46,500 [13.6]	33,350 [9.8]	13,150 [3.9]	11.15	13.00	76	1,525 [720]	46,500 [13.6]	3.54	28,800 [8.4]	2.46	8.30
	RCFL-H*4824A*	46,500 [13.6]	33,350 [9.8]	13,150 [3.9]	11.15	13.00	76	1,525 [720]	46,500 [13.6]	3.54	28,800 [8.4]	2.46	8.30
	21AHL48HM (RCSL-H*4821A*)	47,500 [13.9]	34,250 [10.0]	13,250 [3.9]	11.75	14.00	76	1,600 [755]	46,000 [13.5]	3.64	28,200 [8.3]	2.52	8.50
	21AHL48HM (RCSL-H*4821A*)	47,000 [13.8]	33,850 [9.9]	13,150 [3.9]	11.30	13.00	76	1,525 [720]	46,500 [13.6]	3.58	28,600 [8.4]	2.46	8.50
	UHKL-HM4821 (RCSL-H*4821A*)	47,500 [13.9]	34,100 [10.0]	13,400 [3.9]	11.65	13.50	76	1,575 [743]	46,000 [13.5]	3.64	28,200 [8.3]	2.52	8.50
	UHLL-HM4821 (RCSL-H*4821A*)	47,500 [13.9]	34,250 [10.0]	13,250 [3.9]	11.75	14.00	76	1,600 [755]	46,000 [13.5]	3.64	28,200 [8.3]	2.52	8.50
	UHSL-HM4821 (RCSL-H*4821A*)	47,000 [13.8]	33,850 [9.9]	13,150 [3.9]	11.30	13.00	76	1,525 [720]	46,500 [13.6]	3.58	28,600 [8.4]	2.46	8.50
	24AHL48HM (RCSL-H*4824A*)	48,000 [14.1]	34,550 [10.1]	13,450 [3.9]	12.10	14.00	76	1,625 [767]	46,000 [13.5]	3.70	28,000 [8.2]	2.56	8.50
	UHKL-HM4824 (RCSL-H*4824A*)	48,000 [14.1]	34,500 [10.1]	13,500 [4.0]	12.05	14.00	76	1,625 [767]	46,000 [13.5]	3.70	28,000 [8.2]	2.56	8.60
	UHLL-HM4824 (RCSL-H*4824A*)	48,000 [14.1]	34,550 [10.1]	13,450 [3.9]	12.10	14.00	76	1,625 [767]	46,000 [13.5]	3.70	28,000 [8.2]	2.56	8.50
	UHSL-HM4824 (RCSL-H*4824A*)	47,000 [13.8]	33,850 [9.9]	13,150 [3.9]	11.30	13.00	76	1,525 [720]	46,500 [13.6]	3.58	28,600 [8.4]	2.46	8.50
048DAZ	RCFL-H*4821A*	46,500 [13.6]	33,350 [9.8]	13,150 [3.9]	11.15	13.00	76	1,525 [720]	46,500 [13.6]	3.54	28,800 [8.4]	2.46	8.30
	RCFL-H*4824A*	46,500 [13.6]	33,350 [9.8]	13,150 [3.9]	11.15	13.00	76	1,525 [720]	46,500 [13.6]	3.54	28,800 [8.4]	2.46	8.30
	21AHL48HM (RCSL-H*4821A*)	47,500 [13.9]	34,250 [10.0]	13,250 [3.9]	11.75	14.00	76	1,600 [755]	46,000 [13.5]	3.64	28,200 [8.3]	2.52	8.50
	21AHL48HM (RCSL-H*4821A*)	47,000 [13.8]	33,850 [9.9]	13,150 [3.9]	11.30	13.00	76	1,525 [720]	46,500 [13.6]	3.58	28,600 [8.4]	2.46	8.50
	UHKL-HM4821 (RCSL-H*4821A*)	47,500 [13.9]	34,100 [10.0]	13,400 [3.9]	11.65	13.50	76	1,575 [743]	46,000 [13.5]	3.64	28,200 [8.3]	2.52	8.50
	UHLL-HM4821 (RCSL-H*4821A*)	47,500 [13.9]	34,250 [10.0]	13,250 [3.9]	11.75	14.00	76	1,600 [755]	46,000 [13.5]	3.64	28,200 [8.3]	2.52	8.50
	UHSL-HM4821 (RCSL-H*4821A*)	47,000 [13.8]	33,850 [9.9]	13,150 [3.9]	11.30	13.00	76	1,525 [720]	46,500 [13.6]	3.58	28,600 [8.4]	2.46	8.50
	24AHL48HM (RCSL-H*4824A*)	48,000 [14.1]	34,550 [10.1]	13,450 [3.9]	12.10	14.00	76	1,625 [767]	46,000 [13.5]	3.70	28,000 [8.2]	2.56	8.50
	UHKL-HM4824 (RCSL-H*4824A*)	48,000 [14.1]	34,500 [10.1]	13,500 [4.0]	12.05	14.00	76	1,625 [767]	46,000 [13.5]	3.70	28,000 [8.2]	2.56	8.60
	UHLL-HM4824 (RCSL-H*4824A*)	48,000 [14.1]	34,550 [10.1]	13,450 [3.9]	12.10	14.00	76	1,625 [767]	46,000 [13.5]	3.70	28,000 [8.2]	2.56	8.50
	UHSL-HM4824 (RCSL-H*4824A*)	47,000 [13.8]	33,850 [9.9]	13,150 [3.9]	11.30	13.00	76	1,525 [720]	46,500 [13.6]	3.58	28,600 [8.4]	2.46	8.50
048JAZ	UHSL-HM4821 (RCSL-H*4821A*) ①	47,000 [13.8]	33,850 [9.9]	13,150 [3.9]	11.30	13.00	76	1,525 [720]	46,500 [13.6]	3.58	28,600 [8.4]	2.46	8.50
	RCFL-H*4821A*	46,500 [13.6]	33,350 [9.8]	13,150 [3.9]	11.15	13.00	76	1,525 [720]	46,500 [13.6]	3.54	28,800 [8.4]	2.46	8.30
	RCFL-H*4824A*	46,500 [13.6]	33,350 [9.8]	13,150 [3.9]	11.15	13.00	76	1,525 [720]	46,500 [13.6]	3.54	28,800 [8.4]	2.46	8.30

① Highest sales volume tested combination required by DOE test procedures.

[] Designates Metric Conversions

Performance Data ARI Standard Conditions—UPNL-

Note: Only these combinations of indoor/outdoor units are approved and any other combinations should not be used.

Model Numbers		ARI Cooling Performance							ARI Heating Performance (70°F [21°C] Indoor)				
		80°F [26.5°C] DB/67°F [19.5°C] WB Indoor Air 95°F [35°C] DB Outdoor Air							Outdoor Air 47°F [8.5°C] DB/ 43°F [6°C] WB DOE High Temp.		Outdoor Air 17°F [-8.5°C] DB/ 15°F [-9.5°C] WB DOE Low Temp.		DOE Region IV HSPF
Outdoor Unit UPNL-	Indoor Coil and/or Air Handler	Total Capacity BTU/H [kW]	Net Sens. BTU/H [kW]	Net Latent BTU/H [kW]	EER	SEER	Snd. Rate dB	Indoor CFM [L/s]	BTU/H [kW]	COP	BTU/H [kW]	COP	
Revised 4/21/2008													
048JAZ	21AHL48HM (RCSL-H*4821A*)	47,500 [13.9]	34,250 [10.0]	13,250 [3.9]	11.75	14.00	76	1,600 [755]	46,000 [13.5]	3.64	28,200 [8.3]	2.52	8.50
	21AHS48HM (RCSL-H*4821A*)	47,000 [13.8]	33,850 [9.9]	13,150 [3.9]	11.30	13.00	76	1,525 [720]	46,500 [13.6]	3.58	28,600 [8.4]	2.46	8.50
	UHKL-HM4821 (RCSL-H*4821A*)	47,500 [13.9]	34,100 [10.0]	13,400 [3.9]	11.65	13.50	76	1,575 [743]	46,000 [13.5]	3.64	28,200 [8.3]	2.52	8.50
	UHLL-HM4821 (RCSL-H*4821A*)	47,500 [13.9]	34,250 [10.0]	13,250 [3.9]	11.75	14.00	76	1,600 [755]	46,000 [13.5]	3.64	28,200 [8.3]	2.52	8.50
	24AHL48HM (RCSL-H*4824A*)	48,000 [14.1]	34,550 [10.1]	13,450 [3.9]	12.10	14.00	76	1,625 [767]	46,000 [13.5]	3.70	28,000 [8.2]	2.56	8.50
	UHKL-HM4824 (RCSL-H*4824A*)	48,000 [14.1]	34,500 [10.1]	13,500 [4.0]	12.05	14.00	76	1,625 [767]	46,000 [13.5]	3.70	28,000 [8.2]	2.56	8.60
	UHLL-HM4824 (RCSL-H*4824A*)	48,000 [14.1]	34,550 [10.1]	13,450 [3.9]	12.10	14.00	76	1,625 [767]	46,000 [13.5]	3.70	28,000 [8.2]	2.56	8.50
	UHSL-HM4824 (RCSL-H*4824A*)	47,000 [13.8]	33,850 [9.9]	13,150 [3.9]	11.30	13.00	76	1,525 [720]	46,500 [13.6]	3.58	28,600 [8.4]	2.46	8.50
048YAZ	RCFL-H*4821A*	46,500 [13.6]	33,350 [9.8]	13,150 [3.9]	11.15	13.00	76	1,525 [720]	46,500 [13.6]	3.54	28,800 [8.4]	2.46	8.30
	RCFL-H*4824A*	46,500 [13.6]	33,350 [9.8]	13,150 [3.9]	11.15	13.00	76	1,525 [720]	46,500 [13.6]	3.54	28,800 [8.4]	2.46	8.30
	21AHL48HM (RCSL-H*4821A*)	47,500 [13.9]	34,250 [10.0]	13,250 [3.9]	11.75	14.00	76	1,600 [755]	46,000 [13.5]	3.64	28,200 [8.3]	2.52	8.50
	21AHS48HM (RCSL-H*4821A*)	47,000 [13.8]	33,850 [9.9]	13,150 [3.9]	11.30	13.00	76	1,525 [720]	46,500 [13.6]	3.58	28,600 [8.4]	2.46	8.50
	UHKL-HM4821 (RCSL-H*4821A*)	47,500 [13.9]	34,100 [10.0]	13,400 [3.9]	11.65	13.50	76	1,575 [743]	46,000 [13.5]	3.64	28,200 [8.3]	2.52	8.50
	UHLL-HM4821 (RCSL-H*4821A*)	47,500 [13.9]	34,250 [10.0]	13,250 [3.9]	11.75	14.00	76	1,600 [755]	46,000 [13.5]	3.64	28,200 [8.3]	2.52	8.50
	UHSL-HM4821 (RCSL-H*4821A*)	47,000 [13.8]	33,850 [9.9]	13,150 [3.9]	11.30	13.00	76	1,525 [720]	46,500 [13.6]	3.58	28,600 [8.4]	2.46	8.50
	24AHL48HM (RCSL-H*4824A*)	48,000 [14.1]	34,550 [10.1]	13,450 [3.9]	12.10	14.00	76	1,625 [767]	46,000 [13.5]	3.70	28,000 [8.2]	2.56	8.50
	UHKL-HM4824 (RCSL-H*4824A*)	48,000 [14.1]	34,500 [10.1]	13,500 [4.0]	12.05	14.00	76	1,625 [767]	46,000 [13.5]	3.70	28,000 [8.2]	2.56	8.60
	UHLL-HM4824 (RCSL-H*4824A*)	48,000 [14.1]	34,550 [10.1]	13,450 [3.9]	12.10	14.00	76	1,625 [767]	46,000 [13.5]	3.70	28,000 [8.2]	2.56	8.50
	UHSL-HM4824 (RCSL-H*4824A*)	47,000 [13.8]	33,850 [9.9]	13,150 [3.9]	11.30	13.00	76	1,525 [720]	46,500 [13.6]	3.58	28,600 [8.4]	2.46	8.50
060CAZ	RCFL-H*6024A*	60,000 [17.6]	42,600 [12.5]	17,400 [5.1]	10.70	12.00	76	1,800 [849]	59,000 [17.3]	3.58	38,500 [11.3]	2.64	7.80
	24AHL60HM (RCSL-H*6024A*)	60,500 [17.7]	43,100 [12.6]	17,400 [5.1]	11.15	13.00	76	1,800 [849]	58,500 [17.1]	3.66	38,000 [11.1]	2.72	8.50
	UHKL-HM6024 (RCSL-H*6024A*)	60,500 [17.7]	43,100 [12.6]	17,400 [5.1]	11.15	13.00	76	1,800 [849]	58,500 [17.1]	3.66	38,000 [11.1]	2.72	8.50
	UHLL-HM6024 (RCSL-H*6024A*)	60,500 [17.7]	43,100 [12.6]	17,400 [5.1]	11.15	13.00	76	1,800 [849]	58,500 [17.1]	3.66	38,000 [11.1]	2.72	8.50
	UHSL-HM6024 (RCSL-H*6024A*)	59,000 [17.3]	42,100 [12.3]	16,900 [5.0]	10.40	12.00	76	1,750 [826]	57,000 [16.7]	3.50	36,400 [10.7]	2.60	8.50
060DAZ	RCFL-H*6024A*	60,000 [17.6]	42,600 [12.5]	17,400 [5.1]	10.70	12.00	76	1,800 [849]	59,000 [17.3]	3.58	38,500 [11.3]	2.64	7.80
	24AHL60HM (RCSL-H*6024A*)	60,500 [17.7]	43,100 [12.6]	17,400 [5.1]	11.15	13.00	76	1,800 [849]	58,500 [17.1]	3.66	38,000 [11.1]	2.72	8.50
	UHKL-HM6024 (RCSL-H*6024A*)	60,500 [17.7]	43,100 [12.6]	17,400 [5.1]	11.15	13.00	76	1,800 [849]	58,500 [17.1]	3.66	38,000 [11.1]	2.72	8.50
	UHLL-HM6024 (RCSL-H*6024A*)	60,500 [17.7]	43,100 [12.6]	17,400 [5.1]	11.15	13.00	76	1,800 [849]	58,500 [17.1]	3.66	38,000 [11.1]	2.72	8.50
	UHSL-HM6024 (RCSL-H*6024A*)	59,000 [17.3]	42,100 [12.3]	16,900 [5.0]	10.40	12.00	76	1,750 [826]	57,000 [16.7]	3.50	36,400 [10.7]	2.60	8.50

① Highest sales volume tested combination required by DOE test procedures.

[] Designates Metric Conversions

Performance Data ARI Standard Conditions—UPNL-

Note: Only these combinations of indoor/outdoor units are approved and any other combinations should not be used.

Model Numbers		ARI Cooling Performance							ARI Heating Performance (70°F [21°C] Indoor)				
		80°F [26.5°C] DB/67°F [19.5°C] WB Indoor Air 95°F [35°C] DB Outdoor Air							Outdoor Air 47°F [8.5°C] DB/ 43°F [6°C] WB DOE High Temp.		Outdoor Air 17°F [-8.5°C] DB/ 15°F [-9.5°C] WB DOE Low Temp.		DOE Region IV HSPF
Outdoor Unit UPNL-	Indoor Coil and/or Air Handler	Total Capacity BTU/H [kW]	Net Sens. BTU/H [kW]	Net Latent BTU/H [kW]	EER	SEER	Snd. Rate dB	Indoor CFM [L/s]	BTU/H [kW]	COP	BTU/H [kW]	COP	
Revised 4/21/2008													
060JAZ	UHLL-HM6024 (RCSL-H*6024A*) ①	60,500 [17.7]	43,100 [12.6]	17,400 [5.1]	11.15	13.00	76	1,800 [849]	58,500 [17.1]	3.66	38,000 [11.1]	2.72	8.50
	24AHL60HM (RCSL-H*6024A*)	60,500 [17.7]	43,100 [12.6]	17,400 [5.1]	11.15	13.00	76	1,800 [849]	58,500 [17.1]	3.66	38,000 [11.1]	2.72	8.50
	UHKL-HM6024 (RCSL-H*6024A*)	60,500 [17.7]	43,100 [12.6]	17,400 [5.1]	11.15	13.00	76	1,800 [849]	58,500 [17.1]	3.66	38,000 [11.1]	2.72	8.50
060YAZ	RCFL-H*6024A*	60,000 [17.6]	42,600 [12.5]	17,400 [5.1]	10.70	12.00	76	1,800 [849]	59,000 [17.3]	3.58	38,500 [11.3]	2.64	7.80
	24AHL60HM (RCSL-H*6024A*)	60,500 [17.7]	43,100 [12.6]	17,400 [5.1]	11.15	13.00	76	1,800 [849]	58,500 [17.1]	3.66	38,000 [11.1]	2.72	8.50
	UHKL-HM6024 (RCSL-H*6024A*)	60,500 [17.7]	43,100 [12.6]	17,400 [5.1]	11.15	13.00	76	1,800 [849]	58,500 [17.1]	3.66	38,000 [11.1]	2.72	8.50
	UHLL-HM6024 (RCSL-H*6024A*)	60,500 [17.7]	43,100 [12.6]	17,400 [5.1]	11.15	13.00	76	1,800 [849]	58,500 [17.1]	3.66	38,000 [11.1]	2.72	8.50
	UHSL-HM6024 (RCSL-H*6024A*)	59,000 [17.3]	42,100 [12.3]	16,900 [5.0]	10.40	12.00	76	1,750 [826]	57,000 [16.7]	3.50	36,400 [10.7]	2.60	8.50

① Highest sales volume tested combination required by DOE test procedures.

[] Designates Metric Conversions

Electrical and Physical Data: UPNL-

Model Number UPNL-	ELECTRICAL							PHYSICAL						
	Phase Frequency (Hz) Voltage (Volts)	Compressor		Fan Motor Full Load Amperes (FLA)	Minimum Circuit Ampacity Amperes	Fuse or HACR Circuit Breaker		Outdoor Coil			Refrig. Per Circuit Oz. [g]	Weight		
		Rated Load Amperes (RLA)	Locked Rotor Amperes (LRA)			Minimum Amperes	Maximum Amperes	Face Area Sq. Ft. [m ²]	No. Rows	CFM [L/s]		Net Lbs. [kg]	Shipping Lbs. [kg]	
Rev. 4/21/2008														
018JAZ	1-60-208/230	9/9	48	0.6	12/12	15/15	20/20	8.18 [0.76]	1	1925 [908]	83 [2353]	155 [70.3]	165 [74.8]	
024JAZ	1-60-208/230	12.8/12.8	58.3	0.6	17/17	20/20	25/25	8.18 [0.76]	1	1925 [908]	86 [2438]	155 [70.3]	165 [74.8]	
030JAZ	1-60-208/230	14.1/14.1	73	0.8	19/19	25/25	30/30	20.13 [1.87]	1	2650 [1251]	133 [3771]	200 [90.7]	210 [95.3]	
036CAZ	3-60-208/230	13.2/13.2	88	1.2	18/18	25/25	30/30	23.01 [2.14]	1	3575 [1687]	145 [4111]	246.5 [111.8]	256.5 [116.3]	
036DAZ	3-60-460	6	44	0.6	9	15	15	23.01 [2.14]	1	3575 [1687]	145 [4111]	246.5 [111.8]	256.5 [116.3]	
036JAZ	1-60-208/230	17.9/17.9	112	1.2	24/24	30/30	40/40	23.01 [2.14]	1	3575 [1687]	145 [4111]	246.5 [111.8]	256.5 [116.3]	
042CAZ	3-60-208/230	13.6/13.6	83.1	1.2	19/19	25/25	30/30	23.01 [2.14]	1	3575 [1687]	160 [4536]	257 [116.6]	267 [121.1]	
042DAZ	3-60-460	6.1	41	0.6	9	15	15	23.01 [2.14]	1	3575 [1687]	160 [4536]	257 [116.6]	267 [121.1]	
042JAZ	1-60-208/230	20.5/20.5	109	1.2	27/27	35/35	45/45	23.01 [2.14]	1	3575 [1687]	160 [4536]	257 [116.6]	267 [121.1]	
048CAZ	3-60-208/230	13.7/13.7	83.1	1.2	19/19	25/25	30/30	23.01 [2.14]	1	3575 [1687]	160 [4536]	246 [111.6]	256 [116.1]	
048DAZ	3-60-460	6.2	41	0.6	9	15	15	23.01 [2.14]	1	3575 [1687]	160 [4536]	246 [111.6]	256 [116.1]	
048JAZ	1-60-208/230	21.8/21.8	117	1.2	29/29	35/35	50/50	23.01 [2.14]	1	3575 [1687]	160 [4536]	246 [111.6]	256 [116.1]	
048YAZ	3-60-575	4.8	33	0.5	7	15	15	23.01 [2.14]	1	3575 [1687]	160 [4536]	246 [111.6]	256 [116.1]	
060CAZ	3-60-208/230	15.6/15.6	110	1.2	21/21	25/25	35/35	23.01 [2.14]	1	3350 [1581]	242 [6861]	260 [117.9]	270 [122.5]	
060DAZ	3-60-460	7.8	52	0.6	11	15	15	23.01 [2.14]	1	3350 [1581]	242 [6861]	260 [117.9]	270 [122.5]	
060JAZ	1-60-208/230	26.3/26.3	134	1.2	35/35	45/45	60/60	23.01 [2.14]	1	3350 [1581]	242 [6861]	260 [117.9]	270 [122.5]	
060YAZ	3-60-575	5.8	38.9	0.5	8	15	15	23.01 [2.14]	1	3350 [1581]	242 [6861]	260 [117.9]	270 [122.5]	

Unit Dimensions

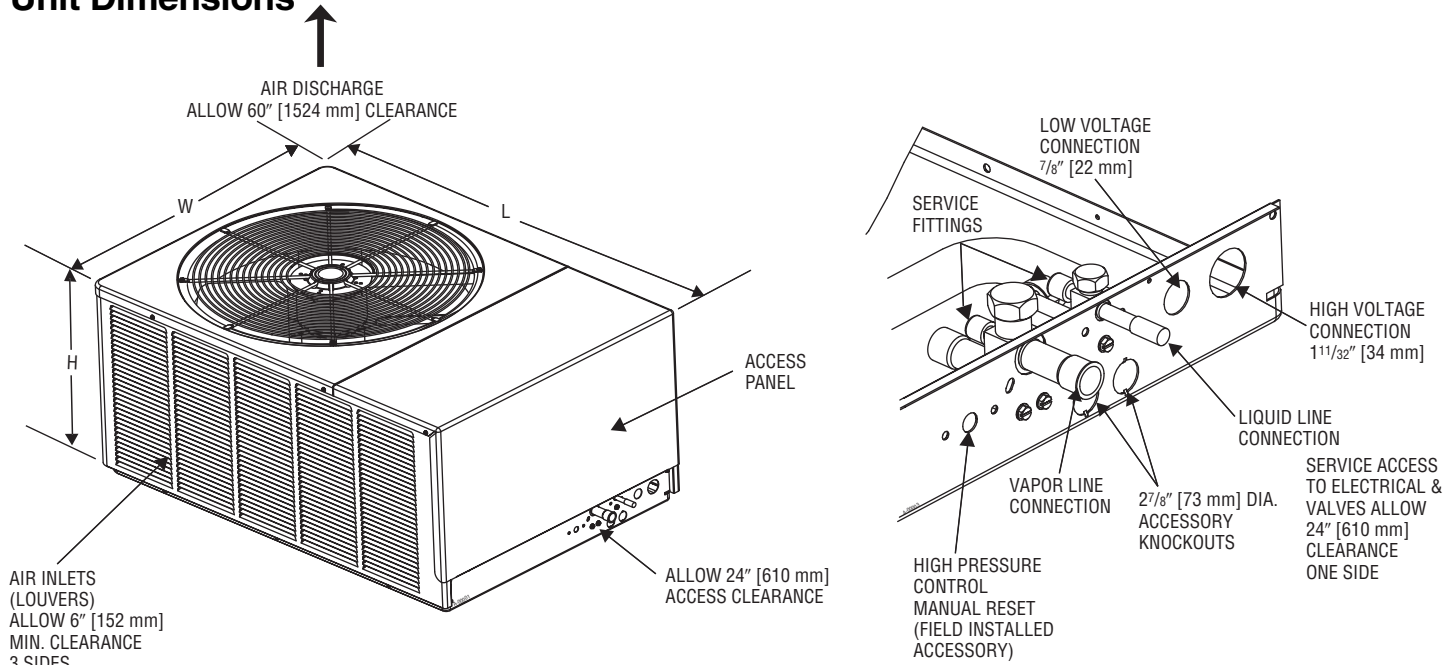

Model Number UPNL-	Height "H" (Inches) [mm]	Length "L" (Inches) [mm]	Width "W" (Inches) [mm]
018/024	19 [482]	40 1/2 [1028]	27 5/8 [701]
030	29 [736]	44 3/8 [1127]	31 1/2 [800]
036/042/048/060	33 [838]	44 3/8 [1127]	31 1/2 [800]

[] Designates Metric Conversions

Heat Pump Refrigerant Line Size Information

System Capacity	Line Size Connection Size (Inch I.D.) [mm]	Line Size (Inch O.D.) [mm]	Liquid Line Sizing (R-410A)					
			Outdoor Unit Above or Below Indoor Coil (Heat Pumps Only)					
			Total Equivalent Length—Feet [m]					
			25 [7.62]	50 [15.24]	75 [22.86]	100 [30.48]	125 [38.10]	150 [45.72]
Maximum Vertical Separation—Feet [m]								
1 1/2 Ton	3/8" [9.53]	1/4 [6.35]	25 [7.62]	40 [12.19]	25 [7.62]	9 [2.74]	N/A	N/A
		5/16 [7.94]	25 [7.62]	50 [15.24]	62 [18.90]	58 [17.68]	53 [16.15]	49 [14.94]
		3/8* [9.53]	25 [7.62]	50 [15.24]	75 [22.86]	72 [21.95]	70 [21.34]	68 [20.73]
2 Ton	3/8" [9.53]	1/4 [6.35]	23 [7.01]	N/A	N/A	N/A	N/A	N/A
		5/16 [7.94]	25 [7.62]	36 [10.97]	29 [8.84]	23 [7.01]	16 [4.88]	9 [2.74]
		3/8* [9.53]	25 [7.62]	50 [15.24]	72 [21.95]	70 [21.34]	68 [20.73]	65 [19.81]
2 1/2 Ton	3/8" [9.53]	1/4 [6.35]	25 [7.62]	N/A	N/A	N/A	N/A	N/A
		5/16 [7.94]	25 [7.62]	49 [14.94]	38 [11.58]	27 [8.23]	17 [5.18]	6 [1.83]
		3/8* [9.53]	25 [7.62]	50 [15.24]	68 [20.73]	65 [19.81]	62 [18.90]	58 [17.68]
3 Ton	3/8" [9.53]	5/16 [7.94]	25 [7.62]	50 [15.24]	37 [11.28]	22 [6.71]	7 [2.13]	N/A
		3/8* [9.53]	25 [7.62]	50 [15.24]	68 [20.73]	63 [19.20]	58 [17.68]	53 [16.15]
3 1/2 Ton	3/8" [9.53]	5/16 [7.94]	25 [7.62]	23 [7.01]	4 [1.22]	N/A	N/A	N/A
		3/8* [9.53]	25 [7.62]	50 [15.24]	43 [13.11]	36 [10.97]	30 [9.14]	24 [7.32]
4 Ton	3/8" [9.53]	3/8* [9.53]	25 [7.62]	46 [14.02]	38 [11.58]	30 [9.14]	22 [6.71]	15 [4.57]
		1/2 [12.7]	25 [7.62]	50 [15.24]	56 [17.07]	55 [16.76]	53 [16.15]	52 [15.85]
5 Ton	3/8" [9.53]	3/8* [9.53]	25 [7.62]	50 [15.24]	56 [17.07]	44 [13.41]	32 [9.75]	20 [6.10]
		1/2 [12.7]	25 [7.62]	50 [15.24]	75 [22.86]	81 [24.69]	79 [24.08]	76 [23.16]

NOTES:
 *Standard line size
 N/A = Application not recommended.

Suction Line Length/Size versus Capacity Multiplier (R-410A)								
Unit Size	1 1/2 Ton	2 Ton	2 1/2 Ton	3 Ton	3 1/2 Ton	4 Ton	5 Ton	
Suction Line Connection Size	3/4" [19.05] I.D.			7/8" [22.23] I.D.				
Suction Line Run—Feet [m]	5/8" [15.88 mm] O.D. Opt. 3/4" [19.05 mm] O.D. Std.*	5/8" [15.88 mm] O.D. Opt. 3/4" [19.05 mm] O.D. Std.* 7/8" [22.23 mm] O.D. Opt.	3/4" [19.05 mm] O.D. Opt. 7/8" [22.23 mm] O.D. Std.*	7/8" [22.23 mm] O.D. Opt. 1 1/8" [28.58 mm] O.D. Std.*				
25' [7.62]	Optional: 1.00 Standard: 1.00 Optional: —	1.00 1.00 —	1.00 1.00 1.00	1.00 1.00 —	1.00 1.00 —	1.00 1.00 —	1.00 1.00 —	
50' [15.24]	Optional: 0.98 Standard: 0.99 Optional: —	0.98 0.99 —	0.96 0.98 0.99	0.98 0.99 —	0.99 0.99 —	0.99 0.99 —	0.99 0.99 —	
100' [30.48]	Optional: 0.95 Standard: 0.96 Optional: —	0.95 0.96 —	0.94 0.96 0.97	0.96 0.97 —	0.96 0.98 —	0.96 0.98 —	0.97 0.98 —	
150' [45.72]	Optional: 0.92 Standard: 0.93 Optional: —	0.92 0.94 —	0.91 0.93 0.95	0.94 0.95 —	0.94 0.96 —	0.95 0.96 —	0.94 0.97 —	

NOTES: [] Designates Metric Conversions
 *Standard line size
 N/A = Using suction line larger than shown in chart will result in poor oil return and is not recommended.

BEFORE PURCHASING THIS APPLIANCE, READ IMPORTANT ENERGY COST AND EFFICIENCY INFORMATION AVAILABLE FROM YOUR RETAILER.

GENERAL TERMS OF LIMITED WARRANTY

Ruud will furnish a replacement for any part of this product which fails in normal use and service within the applicable period stated, in accordance with the terms of the limited warranty.

For Complete Details of the Limited Warranty, Including Applicable Terms and Conditions, See Your Local Installer or Contact the Manufacturer for a Copy.

Condenser Coil leaks caused by factory defects ..Five (5) Years Compressor

JAZTen (10) Years

CAZ, DAZ, YAZFive (5) Years

*Any Other Part

JAZFive (5) Years

CAZ, DAZ, YAZOne (1) Year

*This five year limited warranty is applicable only to single-phase products installed in residential applications on or after January 1, 2001.

NOTES

Before proceeding with installation, refer to installation instructions packaged with each model, as well as complying with all Federal, State, Provincial, and Local codes, regulations, and practices.

**Ruud Heating,
Cooling and
Water Heating**

P.O. Box 17010, Fort Smith, AR 72917



"In keeping with its policy of continuous progress and product improvement, Ruud reserves the right to make changes without notice."